

Samarkand I Solar PV and  
BESS Project  
Republic of Uzbekistan

Environmental and Social Impact  
Assessment (ESIA)

**Volume I: Non-Technical  
Summary**



September 2025, v1.6

## DOCUMENT INFORMATION

<b>PROJECT NAME</b>	Samarkand I Solar PV and BESS Project
<b>5Cs PROJECT NUMBER</b>	1305/001/153
<b>DOCUMENT TITLE</b>	Environmental and Social Impact Assessment (ESIA) Report
<b>CLIENT</b>	ACWA Power
<b>5Cs PROJECT MANAGER</b>	Catherine Sarunday
<b>5Cs PROJECT DIRECTOR</b>	Ken Wade

## DOCUMENT CONTROL

VERSION	DATE	DESCRIPTION	AUTHOR	REVIEWER	APPROVER
1.0	7/08/2024	Environmental and Social Impact Assessment (Volume I) – Non-Technical Summary for ADB early disclosure	CS	KW	MB
1.1	7/08/2024	Updates for EBRD disclosure	CS	KW	MB
1.2	6/12/2024	Updates for EBRD disclosure	CS	KW	MB
1.3	10/12/2024	Updates for EBRD disclosure	CS	KW	MB
1.4	16/05/2025	Updates for final disclosure	CS	KW	MB
1.5	1/09/2025	Updates for final disclosure	CS	KW	MB
1.6	8/09/2025	Updates for final disclosure	CS	KW	MB



1	Financial Capital	Regardless of location, mode of delivery or function, all organisations are dependent on
2	Social Capital	<i>The 5 Capitals of Sustainable Development</i> to enable long term delivery of its products or services.
3	Natural Capital	Sustainability is at the heart of everything that
4	Manufactured Capital	5 Capitals achieves. Wherever we work, we strive to provide our clients with the means to maintain and enhance these stocks of capital assets.
5	Human Capital	

## DISCLAIMER

5 Capitals cannot accept responsibility for the consequences of this document being relied upon by any other party, or being used for any other purpose.

This document contains confidential information and proprietary intellectual property. It should not be shown to other parties without consent from the party which commissioned it.

This document is issued for the party which commissioned it and for specific purposes connected with the above-identified project only. It should not be relied upon by any other party or used for any other purpose.

# CONTENTS

1	INTRODUCTION	6
1.1	Project Rationale and Roadmap	6
1.2	E&S Assessment Background	7
1.2.1	National EIA	7
1.2.2	Bankable ESIA	7
1.3	Objectives of the ESIA Non-Technical Summary	8
2	PROJECT DESCRIPTION	10
2.1	Key Project Information	10
2.2	Project Location	10
2.3	Project Facilities	14
2.3.1	Main facilities	15
2.3.2	Associate facilities	17
2.3.3	Ancillary facilities	17
2.4	Construction Activities, Resources and Waste	18
2.4.1	Construction activities	18
2.4.2	Construction equipment	19
2.4.3	Construction materials and waste	19
2.4.4	Power demand	20
2.4.5	Construction workforce	20
2.5	Operation and Maintenance Activities, Resources and Waste	21
2.5.1	Operational activities	21
2.5.2	Operational equipment	21
2.5.3	Operational materials and waste	21
2.5.4	Power demand	22
2.5.5	Operational workforce	22
2.6	Project Milestones	22
2.7	Sazagan Power Purchase Scheme	22
3	LAND-USE CONTEXT AND KEY E&S RECEPTORS	25
3.1	Existing Land-Use and Land Acquisition	25
3.1.1	100 MW PV Power Plant	25
3.1.2	400 MW PV power plant	26
3.1.3	Pooling station	27

3.1.4	Nurobod BESS and underground cable	27
3.1.5	70-km and 4.9-km OHTLs	27
3.1.6	11-km and 13-km LILO OHTLs	28
3.2	Initial Identification of E&S Impact Receptors	29
3.3	Land Acquisition Process	31
3.4	Analysis of Project Alternatives	32
<b>4</b>	<b>STAKEHOLDER ENGAGEMENT</b>	<b>33</b>
4.1	Stakeholder Engagement Objectives	33
4.2	Stakeholder mapping and categorization	33
4.3	Stakeholder Engagement Methods	34
4.4	Stakeholder Inputs for ESIA	34
4.5	Forward Stakeholder Engagement	36
4.6	Grievance Redress Mechanism	36
<b>5</b>	<b>SUMMARY OF ENVIRONMENTAL AND SOCIAL IMPACTS</b>	<b>41</b>
5.1	Geology, Soils and Hydrology	41
5.2	Solid Waste and Wastewater	42
5.3	Terrestrial and Aquatic Ecology	44
5.3.1	Flora and habitat types	44
5.3.2	Herptiles	45
5.3.3	Non-volant mammals	46
5.3.4	Bats	47
5.3.5	Avifauna	47
5.3.6	Aquatic ecology	48
5.4	Noise and Vibration	51
5.5	Air Quality	52
5.6	Landscape and Visual Amenity	53
5.7	Traffic and Transportation	55
5.8	Cultural Heritage	56
5.9	Socioeconomics	57
5.10	Community Health, Safety and Security	59
5.11	Labour Conditions and Occupational Health and Safety	61
5.12	Climate Risks	62
<b>6</b>	<b>ENVIRONMENTAL AND SOCIAL MANAGEMENT AND MONITORING</b>	<b>63</b>

---

6.1 Independent Auditing and Monitoring	63
APPENDIX A – PROJECT CONTACT INFORMATION	65

## LIST OF ABBREVIATIONS

ABBREVIATION	MEANING
<b>ADB</b>	Asian Development Bank
<b>AoI</b>	Area of Influence
<b>BAP</b>	Biodiversity Action Plan
<b>BESS</b>	Battery Energy Storage System
<b>BMEP</b>	Biodiversity Monitoring and Evaluation Plan
<b>BMP</b>	Biodiversity Management Plan
<b>CESMP</b>	Construction Environmental & Social Management Plan
<b>CHA</b>	Critical Habitat Assessment
<b>CLOs</b>	Community Liaison Officers
<b>DFIs</b>	Development Finance Institutions
<b>EBRD</b>	European Bank for Reconstruction and Development
<b>EIA</b>	Environmental Impact Assessment
<b>ESIA</b>	Environmental and Social Impact Assessment
<b>ESMS</b>	Environmental and Social Management System
<b>FGD</b>	Focus Group Discussions
<b>GBV</b>	Potential Gender-Based Violence
<b>GCM</b>	Global Climate Models
<b>GHG</b>	Greenhouse gas
<b>GIIP</b>	Good International Industry Practice
<b>HGVs</b>	Heavy Goods Vehicles
<b>HSSE</b>	Health Safety Security and Environmental
<b>HVAC</b>	Heating, Ventilation and Air Conditioning
<b>IFIs</b>	International Financial Institutions
<b>IPs</b>	Indigenous Peoples
<b>JBIC</b>	Japan Bank for International Cooperation
<b>JSC the</b>	Joint-Stock Company
<b>KIIs</b>	Key Informant Interviews
<b>LALRP</b>	Land Acquisition and Livelihood Restoration Plan
<b>LGA</b>	Local Government Authorities
<b>LLA</b>	Land Lease Agreement
<b>MEEPCC</b>	Ministry of Ecology, Environmental Protection and Climate Change
<b>NEGU</b>	National Electric Grid of Uzbekistan
<b>NG</b>	Net Gain
<b>NGOs</b>	Non-Governmental Organizations
<b>NNL</b>	Not Net Loss
<b>NTS</b>	Non-Technical Summary
<b>O&amp;M</b>	Operation and Maintenance

ABBREVIATION	MEANING
<b>OESMP</b>	Operational Environmental & Social Management Plan
<b>OHTL</b>	Overhead Transmission Line
<b>PAC</b>	Project-Affected Communities
<b>PICs</b>	Project Information Centres
<b>PPA</b>	Power Purchase Agreement
<b>PSs</b>	IFC Performance Standards
<b>PV</b>	Photo-Voltaic
<b>SCA</b>	Social Compliance Audit
<b>SEA</b>	Sexual Exploitation and Abuse
<b>SEP</b>	Stakeholder Engagement Plan
<b>SSP</b>	Shared Socioeconomic Pathway
<b>VECs</b>	Valued Environmental Components
<b>VP</b>	Vantage Point

# 1 INTRODUCTION

## 1.1 Project Rationale and Roadmap

Uzbekistan is amongst the fastest growing economies in the Central Asian region, with a steady demand for energy. In 2018, the country's power consumption reached 50 million TWh, and the domestic demand for power is projected to rise at an annual rate of 4%, due to continued population growth and industrial expansion.

The steady uptrend in power consumption, declining yield of aged power plants and emergent climatic pressures have led to unprecedented power supply shortages, particularly within the regions of Tashkent, Andijan, Namangan, Ferghana, Samarkand, and Surkhandarya. In December 2022, severe grid overload ensued from widespread spikes in electrical demand for domestic heating under extreme winter temperatures, culminating in a series of power blackouts across Tashkent Region. The emerging power crisis in Uzbekistan has prompted a priority agenda for the development of the country's renewable energy base. This plan aligns with the country's policy shift towards decarbonization and a greener economy.

On 19 March 2023, the Joint-Stock Company (JSC) National Electric Grid of Uzbekistan (NEGU) entered into a Power Purchase Agreement (PPA) with ACWA Power (hereinafter the Project Developer), for the fast-track development and operation of two PV power plants (100 MW and 400 MW) and a 500-megawatt hour (MWh) Battery Energy Storage System (BESS) in Samarkand Region, hereinafter referred to as the Project. The agreement also includes the construction of related interconnection facilities (i.e., sub-stations and powerlines). The agreement will be executed over a period of 25 years and 20 years from the Commercial Operation Dates (COD) for the PV power plant and BESS components respectively. Upon the completion of the agreement term, the project facilities will be handed over to the off-taker (NEGU) for subsequent operation and maintenance (O&M).

To this end, the project company, ACWA Power Sazagan Solar 1 LLC, was incorporated on 2 March 2023. The Project Developer is seeking to finance the Project in cooperation with Development Finance Institutions (DFIs) including the Asian Development Bank (ADB), European Bank for Reconstruction and Development (EBRD), International Finance Corporation (IFC), and Japan Bank for International Cooperation (JBIC) (hereinafter the Project Lenders).

To ensure comprehensive risk management and permitting, in keeping with applicable E&S appraisal criteria and performance standards, the Project Developer has appointed 5 Capitals (hereinafter the Consultant) to undertake a bankable Environmental and Social Impact

Assessment (ESIA) for the Project. The Consultant has engaged Juru, NBT and Index Consulting as a local sub-consultants, for support with completion of the national EIA, ESIA and Land Acquisition and Livelihood Restoration Plan (LALRP) surveys, and related stakeholder engagement.

## 1.2 E&S Assessment Background

### 1.2.1 National EIA

The Project is subject to a phased national EIA study aimed at assessing potential E&S impacts and establishing appropriate management measures, in accordance with national laws and regulations. The outcomes of this appraisal are positive conclusions for each stage of the study for all project components (i.e., PV power plant, BESS and powerlines).

The first stage of the national EIA studies for the different project facilities was undertaken by Juru, and a total of four preliminary EIA (PZVOS) reports were submitted to the Regulator (i.e., Ministry of Ecology, Environmental Protection and Climate Change). The Regulator issued positive conclusions for all four EIA studies and E&S management plans, thereby permitting the completion of all construction works planned under the Project and obviating the requirement for the second (conditional) stage of the national EIA (ZVOS) in advance of construction.

The third stage of the national EIA studies (i.e., ZEP) will be initiated following the completion of construction for each facility. Accordingly, positive conclusions on the Statements on Environmental Consequences (ZEP) shall precede the start of any commissioning and Operation and Maintenance (O&M) activities planned under the Project.

### 1.2.2 Bankable ESIA

With DFI financing, the Project is also subject to a bankable ESIA study aimed at ensuring (i) statutory E&S compliance, (ii) delivery on ratified E&S convention commitments, and (iii) alignment with the mandates, policy objectives, national and sectoral strategies, and E&S performance standards observed by the Project Lenders, including the IFC E&S Performance Standards and the ADB Safeguard Policy Statement.

The bankable ESIA commenced with the preparation of an ESIA Scoping Report, which served to identify the key E&S risks and impacts associated with the Project's planned activities, and the extent of baseline surveys and stakeholder engagement to assess potential impacts, in order for adequate prevention and mitigation planning. The ESIA scoping report was submitted to the Project Lenders and Lenders' Environmental and Social Advisor (LESA) in February 2024, for technical reviews and feedback.

The full-on ESIA study was carried out and documented in the ESIA documents package (i.e., Volume I through IV). Volume II (main text) of the working ESIA report was submitted to the LEA and Project Lenders between April and August 2024, for technical reviews and feedback prior to early public (online) disclosure. Beyond the ESIA report, the final E&S safeguard documents prepared for the Project include the Critical Habitat Assessment (CHA), Land Acquisition and Livelihood Restoration Plan (LALRP) and Stakeholder Engagement Plan (SEP).

The objectives of this ESIA in relation to this project include the following:

- Review of compliance obligations, including applicable laws and regulations, binding international conventions, and lender-specific E&S performance standards.
- Identification of Valued Environmental Components (VECs) situated in and around the project footprint, to determine potential Environmental and Social (E&S) impacts and Areas of Influence (Aols).
- Analysis of project alternatives (i.e., technical and locational) in the context of potential E&S impacts, to determine those that can be implemented with the least breadth and severity of adverse impacts, and with E&S project benefits.
- Assessment of baseline conditions prior to the development of the Project through secondary research and specialized, contextual baseline surveys.
- Detailed assessment of potential E&S impacts in the Project's construction and O&M phases.
- Assessment of potential impacts related to involuntary physical and economic displacement, to enable the development of a responsive Livelihood Restoration Plan for the Project, in line with lender requirements.
- Meaningful stakeholder engagement to enable the delivery of introductory project information, disclosure of the ESIA process, potential impacts and proposed safeguards, whilst providing communication channels for expert and local feedback in relation to project alternatives, potential impacts and risks, and impact management measures.
- Determination of applicable impact management measures and monitoring requirements to be implemented in order to avoid, mitigate and offset potential impacts (on hierarchical basis), whilst enhancing prospective E&S benefits associated with the Project.
- Prepare a framework from which the construction phase and operational phase respective environmental and social management systems and plans can be developed and implemented.

### 1.3 Objectives of the ESIA Non-Technical Summary

The Non-Technical Summary (NTS) of the ESIA provides a summary description of the project rationale, design, forward implementation plan, E&S risk assessment framework, and the

outcomes of baseline studies, stakeholder engagement and impact analyses to evaluate potential E&S impacts associated with project activities. In addition, the NTS outlines the risk and impact management measures for key potential impacts and risks, as well as the principal monitoring considerations for impacts and management measures alike.

The NTS constitutes Volume I of the ESIA package. Please refer to Volume II of the project ESIA, for further information on the ESIA process, outcomes and conclusion. Additional information with regard to stakeholder engagement and the management of the Project's impacts on land tenure and livelihoods is provided in the Stakeholder Engagement Plan (SEP) and Land Acquisition and Livelihood Restoration Plan (LALRP) prepared in tandem with the project ESIA.

## 2 PROJECT DESCRIPTION

### 2.1 Key Project Information

**Table 2-1 Key Project Information**

<b>PROJECT TITLE</b>	Samarkand I Solar PV and BESS Project
<b>PROJECT DEVELOPER</b>	ACWA Power
<b>PROJECT COMPANY</b>	ACWA Power Sazagan Solar 1 LLC
<b>OFF TAKER</b>	JSC National Electric Grid of Uzbekistan
<b>EPC CONTRACTOR</b>	Larsen and Tourbo (L&T)
<b>O&amp;M COMPANY</b>	NOMAC
<b>ENVIRONMENTAL CONSULTANT</b>	5 Capitals Environmental and Management Consulting (5 Capitals) PO Box 119899, Dubai, UAE Tel: +971 (0) 4 343 5955, Fax: +971 (0) 4 343 9366 www.5capitals.com
<b>POINT OF CONTACT</b>	Ken Wade (Director), Ken.wade@5capitals.com

### 2.2 Project Location

The project consists of three main components which include (i) the 400 MW PV power plant, (ii) 500 MWh BESS and its interconnection cable, (iii) 70-km 220kv Overhead Transmission Line (OHTL), as well as two Loop-In-Loop-Out Connections (LILOs).

The 100 MW and 400 MW PV power plants are located in Nurobod District, about 17 and 78 km from Samarkand City respectively. The BESS and the 150-metre underground cable connecting the facility to an adjacent sub-station are located in Pstdargom District, approximately 12 km from Samarkand City. The planned power plants are linked to the sub-station by a 4.9-kilometre OHTL and 70-kilometre OHTL respectively, each with a rating of 220 kilovolts (kV). This sub-station will be developed as part of the ongoing Samarkand II solar PV and BESS project.

In addition, the Project will involve the development of two Loop-In-Loop-Out (LILO) connections, which will connect the new sub-station to the grid. Two northward 11-kilometre, 220 kV OHTLs and two westward 19-kilometre, 220 kV LILO OHTLs will extend from the sub-station towards two existing OHTLs.

The relative locations of the planned project facilities are illustrated in Figure 2-1 to Figure 2-6 below.

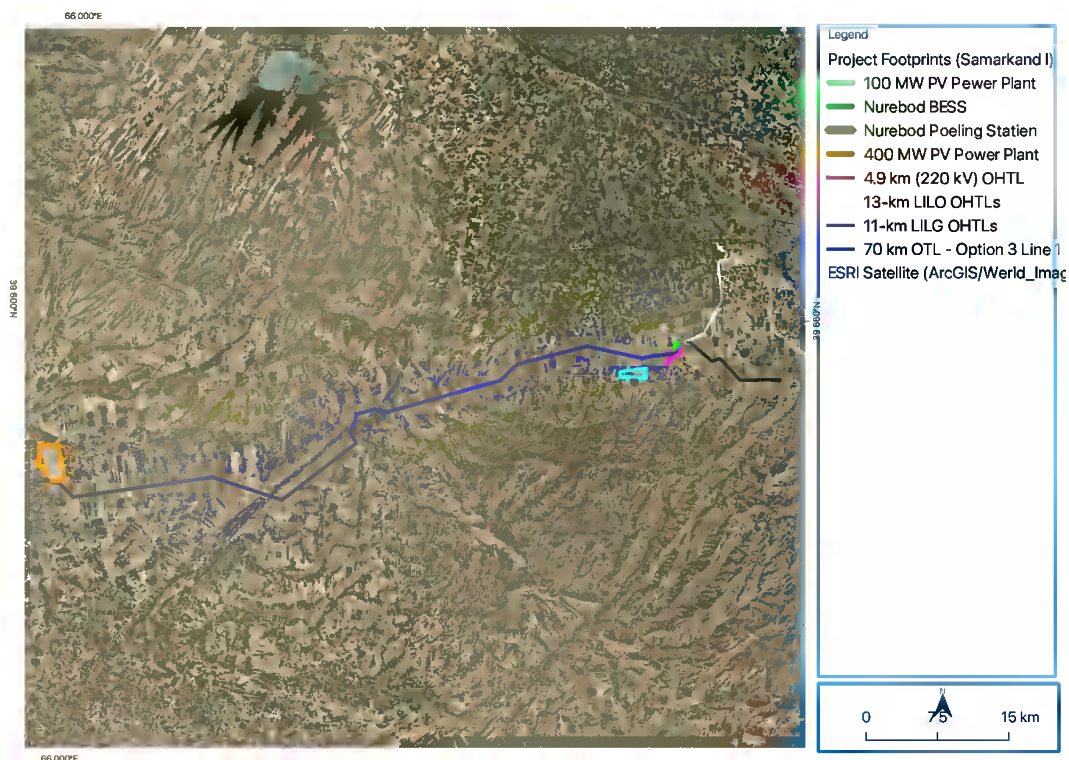

Figure 2-1 Relative locations of the project sites in Samarkand Region (zoomed out)

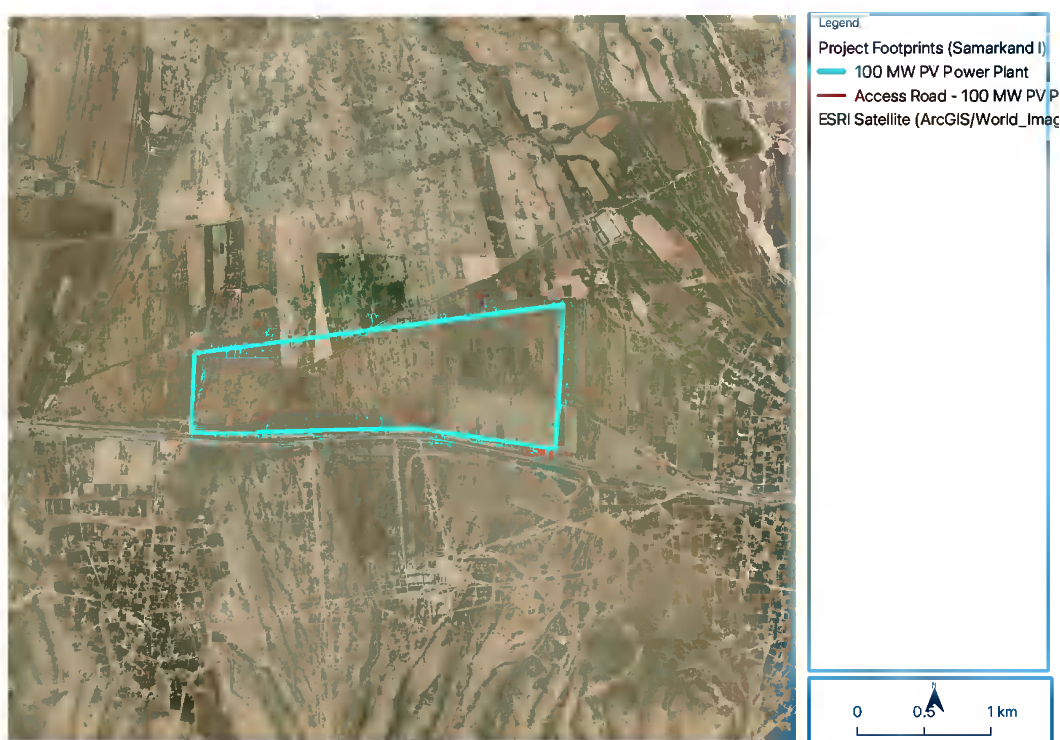

Figure 2-2 Planned 100 MW PV power plant and access road

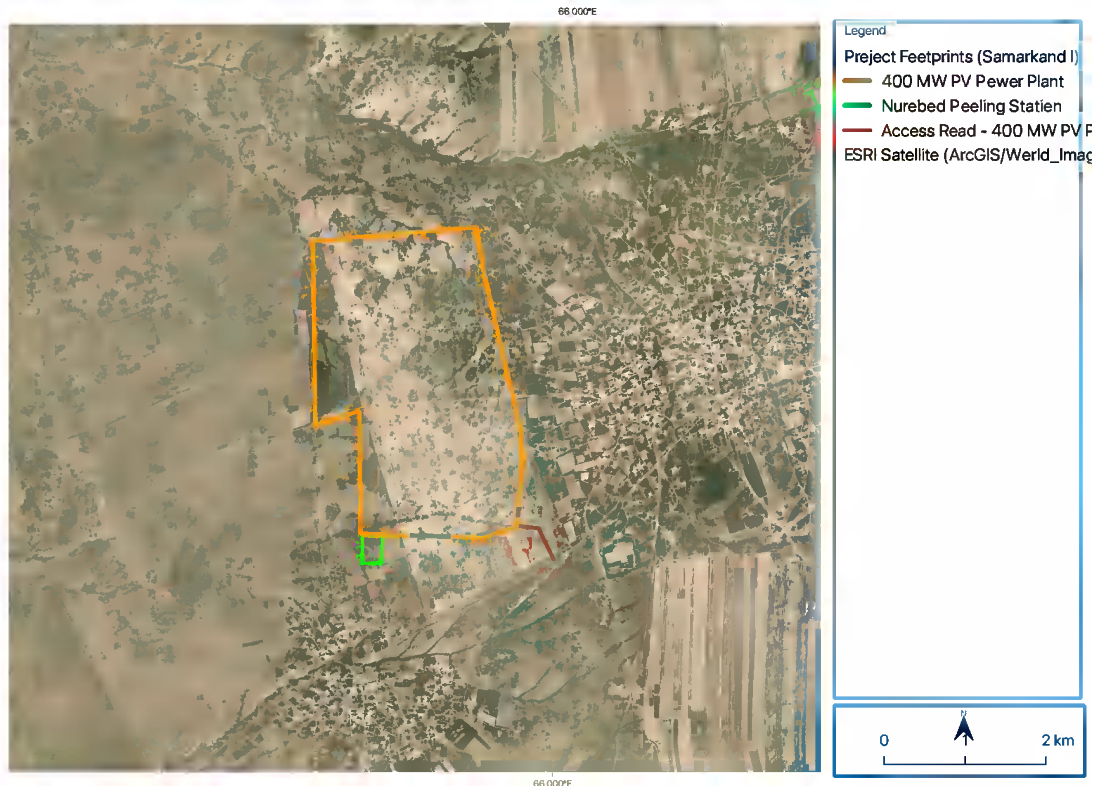

Figure 2-3 Planned 400 MW PV power plant, pooling station and access road

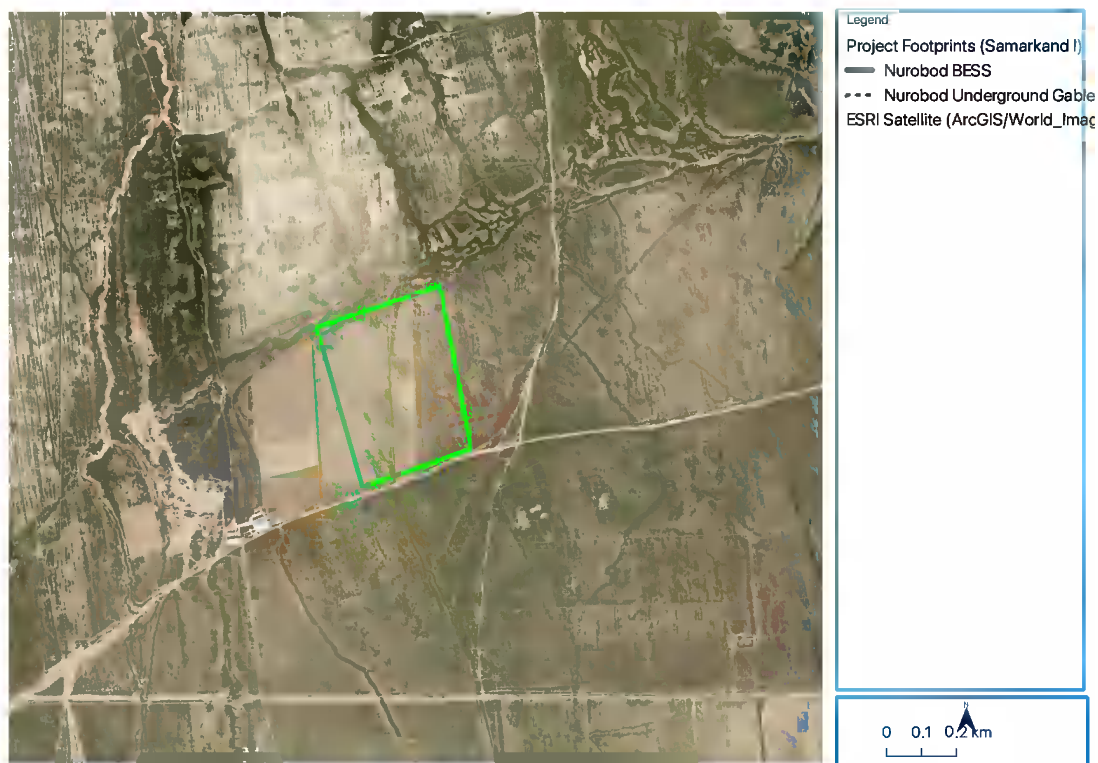

Figure 2-4 Planned BESS and underground cable

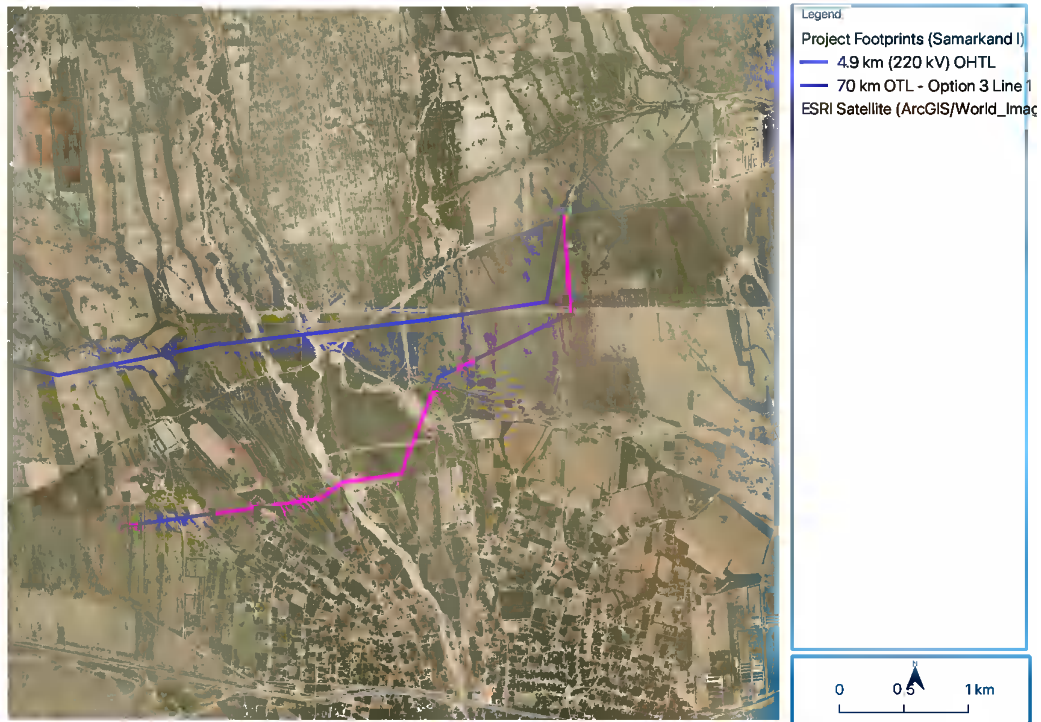

Figure 2-5 Planned 4.9-km OHTL

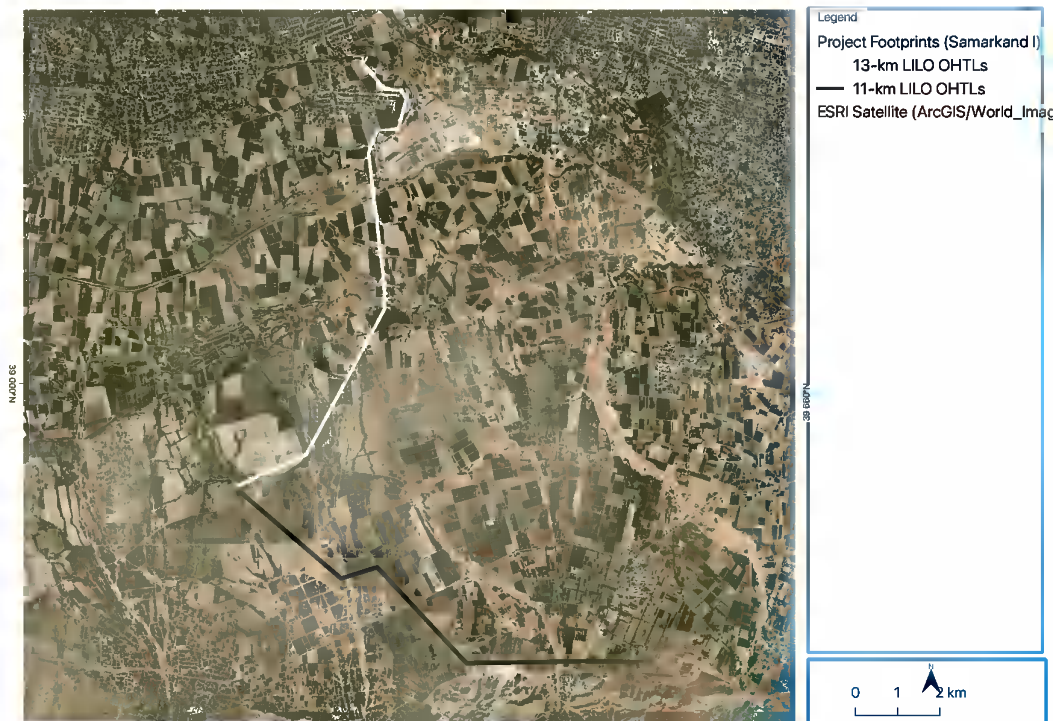

Figure 2-6 Planned LILLO OHTLs

Indicative GPS coordinates for the non-linear project facilities are provided in the table below.

**Table 2-2 GPS coordinates for the project site boundaries**

LATITUDE	LONGITUDE
<b>100 MW PV power plant site</b>	
66.67100788	39.5478947
66.70309628	39.551831
66.70265133	39.54206311
66.69050389	39.54323008
66.67086644	39.54257615
<b>400 MW PV power plant site</b>	
65.96305235	39.4610762
65.98647932	39.46322421
65.99377415	39.44100089
65.99430429	39.43733709
65.99368476	39.43003983
65.98897432	39.42864873
65.97129917	39.42866702
65.97054867	39.44231101
65.96431009	39.44062496
65.94276584	39.40046985
<b>Nurobod BESS site</b>	
65.97156865	39.42845134
65.97454371	39.42844425
65.97455479	39.42544241
65.97167309	39.42538893
<b>Pooling station site</b>	
65.97156865	39.42845134
65.97454371	39.42844425
65.97455479	39.42544241
65.97167309	39.42538893

## 2.3 Project Facilities

Project facilities planned for the Project's construction and operational phases can be split into several categories, based on their relation to the project and the financing agencies involved in the development of these facilities.

### 2.3.1 Main facilities

The main facilities refer to facilities planned as part of the project, which are of primary importance to the Project's operational objectives and funded by the Project Lenders.

These facilities comprise the solar (PV) power plants and the BESS. The planned PV power plant will serve the following main functions:

- Generation of solar power.
- Conditioning of the raw electrical output, for conformity with the operational standards of the recipient utility grid.
- Evacuation of power harnessed by the PV power plant to the recipient utility grid.

The main functions of the BESS include:

- Storage of surplus power in the utility grid during periods of off-peak demand.
- Controlled discharge of stored power to the utility grid during periods of limited production and/or peak-demand.

#### 2.3.1.1 Solar power (PV) plant

The solar (PV) plants sited at different locations within Nurobod District will operate at a capacity of 100 MW and 400 MW, with a total estimated lifetime yield of 6,324,686 MWh and 25,298,744 MWh respectively. The PV power plant components involved in the generation of electricity are described in the following sub-sections.

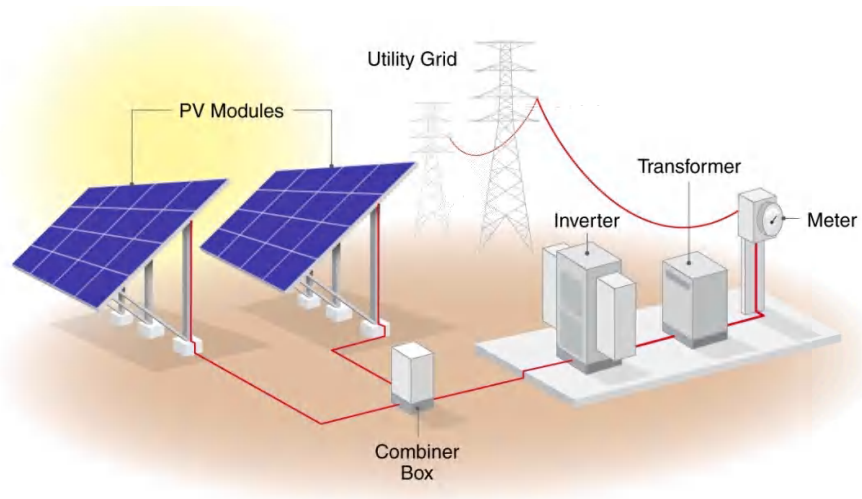

**Figure 2-7 Illustration of the configuration of utility-scale PV power plants**

The PV power plant consists of the following facilities:

- Solar modules, panels and strings

- Solar trackers and mounting system
- Central combiner boxes
- Inverters
- Medium-voltage step-up transformers
- Collector sub-station

### 2.3.1.2 Battery Energy Storage System

The Project will also involve the establishment of a standalone 500 MWh AC-coupled Battery Energy Storage System (BESS), which will be developed close to an existing sub-station. The BESS facility will serve the following main functions:

- Storage of electrical energy from power sources feeding into the project-associated utility grid during off-peak grid time, and the dispatch of the operating reserves in the event of grid congestion (i.e., instances of power demand exceeding power supply).
- Stabilization of the frequency of the project-associated utility grid by provisioning power reserves to equalize power demand and power supply within the grid.

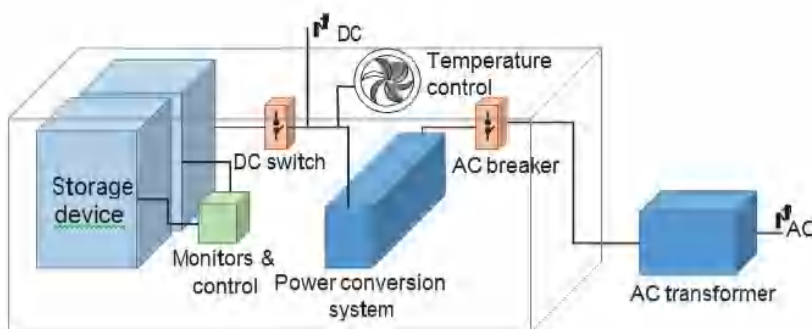

**Figure 2-8 General schematic of a BESS facility**

The BESS consists of the following facilities:

- Battery assembly
- Battery Management System (BMS)
- Power Conversion System (PCS)
- Grid connection
- Energy Management System
- Heating, Ventilation and Air Conditioning System (HVAC)

### **2.3.1.3 70-km OHTL**

The 220-kV 70-km OHTL will convey power from the 400 MW PV plant to the recipient 220kV/500 kV sub-station in Nurobod District.

### **2.3.1.4 Pooling station**

Certain facilities planned under the Samarkand I PV and BESS project are located alongside (adjacent) to the same set of facilities planned under the Samarkand II PV and BESS project (planned concurrently by the Project Developer). Specifically, the 400 MW PV power plant and its respective 70-km OHTL are located alongside the 500 MW PV power plant and 70-km OHTL planned under the Samarkand II project. During operation, the power from the Samarkand I 400 MW PV power plant will be exported to Nurobod sub-station, via the 70-km OHTL, and power from the adjacent Samarkand II 500 MW PV power plant will be exported to the same sub-station through a separate, dedicated 70-km OHTL planned under the Samarkand II project. A pooling station planned under the Samarkand I project will be situated between the two PV power plants.

## **2.3.2 Associate facilities**

### **2.3.2.1 11-km LILO OHTLs**

The project will involve the development of two, parallel 11-kilometre LILO powerlines, which will connect the planned Nurobad sub-station to an existing operational OHTL.

### **2.3.2.2 13-km LILO OHTLs**

The project will involve the development of two, parallel 13-kilometre LILO powerlines, which will connect the planned Nurobad sub-station to another existing operational OHTL.

## **2.3.3 Ancillary facilities**

This set of project facilities will be established for auxiliary purposes during the Project's construction and operational phases, such as general maintenance and connection to enabling utility infrastructure.

### **2.3.3.1 Construction enabling and maintenance**

Ancillary facilities refer to facilities which are planned as part of the project, which are (i) of secondary importance to the Project's operational objectives and (ii) directly owned, operated, or managed by the Project Developer, EPC Contractor, and O&M Company.

This set of project facilities will be established for auxiliary purposes during the Project's construction and operational phases, such as general maintenance and connection to enabling utility infrastructure:

- Access roads
- Laydown areas
- Concrete supply
- Construction site offices and welfare facilities
- Sanitation facilities
- Solid waste facilities
- Security system

Existing accommodation facilities (i.e., rental homes and hotels) in Nurobod district centre, Juma Town, and Samarkand City will be used for labour accommodation at the Limited Notice to Proceed (LNTP) or early work stage of construction. Depending on the outcomes of the housing survey in the project affected district, a construction labour camp may be established or leased near the project sites, for labour housing at the Notice to Proceed (NTP) or main works stage.

### **2.3.3.2 Operations and maintenance**

The following ancillary facilities will be established to enable construction activities planned under the Project.

- Drainage system
- Fire safety system
- Lightning protection system
- Operation and maintenance office
- Warehouses
- Sanitation facilities
- Solid waste storage facilities
- Security system

## **2.4 Construction Activities, Resources and Waste**

### **2.4.1 Construction activities**

The Project's construction phase will entail the following main activities:

- Mobilization and early construction works
- Civil works
- Electrical and mechanical works
- Demobilization

## 2.4.2 Construction equipment

The main equipment to be employed for construction activities includes excavators, bulldozers, mobile cranes, forklifts, trucks, trenchers, compactors, welding machines, and power generators. A non-exhaustive list of major construction equipment is provided in Table 2-3 below.

**Table 2-3 Provisional inventory of construction equipment**

BATTERY UNITS	TOTAL NUMBER
Bulldozer	2
Excavator	2
Mobile crane	2
Truck	2
Truck-mounted drill rig	6

## 2.4.3 Construction materials and waste

The planned construction activities will require a host of raw materials and generate various streams of liquid and solid refuse, which will require temporary and controlled on-site storage, prior to handover to licensed contractors for disposal, off-site treatment and/or recycling at designated sites.

Table 2-4 provides a list of the main construction materials, which will be used during the Project's construction phase.

**Table 2-4 Estimated quantities of raw construction materials**

MATERIAL	QUANTITY
Water	84,503 m <sup>3</sup> per year
Concrete	20,000 tonnes
Steel	5,000 tonnes
Fuel (for generator and motorized machinery)	1.2 million litres

Water supplies for construction activities will be tankered to construction sites, from suppliers within nearby urban centres, such as Nurobod District Centre, Juma Town and Samarkand City.

An overview of construction-phase waste streams and their respective estimated quantities is provided in Table 2-5 below.

**Table 2-5 Estimated quantities of construction waste**

MATERIAL	QUANTITY
Sewage	1,693 m <sup>3</sup> per year
Solid waste	600 tonnes

#### 2.4.4 Power demand

Construction work for the development of the PV power plant, BESS, and powerlines will require a monthly average of 132,666 KWh. The Project's total power demand will be met using generator sets, which will be stationed at each construction site. Full-time and standby generators will also be mobilized for construction labour camps<sup>1</sup>.

No on-site fuel storage and on-site re-fuelling will be undertaken within the project sites at the LNTP stage. However, the establishment of fuel storage facilities will commence prior to the start of NTP activities (in December 2024).

#### 2.4.5 Construction workforce

The Project Company will employ a total of 16 employees during construction. The Project Developer has appointed Larsen and Tourbo (L&T) as EPC Contractor for the Project. The construction workforce will comprise skilled and semi-skilled labour, with a peak total of 1,185 workers. A sizeable fraction of the contracted workforce (i.e., 40-60%) will be foreign, however recruitment for readily available specialists and blue-collar jobs will be reserved for Uzbekistan nationals and residents of the Project's affected communities, to the extent feasible.

Any centralized accommodation facilities (i.e., new or existing) will be audited to ensure accommodation and sanitary conditions meet the requirements of the IFC/ EBRD guidelines for labour accommodation.

Beyond contracted labour, the Project will engage a supply chain including labour employed in the upstream production of materials and components used for the manufacture of

<sup>1</sup> Camp locations were not determined at the time of this assessment

essential power equipment. The primary supplier of electrical equipment (including PV modules) for the Project is JA Solar.

## 2.5 Operation and Maintenance Activities, Resources and Waste

### 2.5.1 Operational activities

The following Operation and Maintenance (O&M) activities will be carried out over the course of the Project's operational lifetime:

- Commissioning and Plant Handover
- Scheduled/ preventative maintenance
- Scheduled/ preventative maintenance
- Unscheduled/ corrective maintenance
- Performance monitoring, production forecasting and reporting

### 2.5.2 Operational equipment

Key equipment that will be used at the Project's O&M phase mainly includes miscellaneous spare equipment parts/ devices (i.e., batteries, fuses etc.).

### 2.5.3 Operational materials and waste

Materials required for O&M activities will be delivered to PV power plant and BESS sites upon demand and stored within on-site warehouses. These materials will include water for sanitary and other maintenance activities. The automated cleaning system for the PV panels will strip panel surfaces of dust and debris using dry brush technology (i.e., without the application of water). Operation and maintenance will also generate various streams of liquid and solid refuse, which will require temporary and controlled on-site storage, prior to handover to licensed contractors for disposal, treatment and/or recycling at designated sites.

Operation-phase waste materials potentially include:

- Electronic waste.
- Spent oils.
- Domestic solid refuse from site offices.
- Domestic wastewater/ sewage.

## 2.5.4 Power demand

Auxiliary power supply is required to operate inverter control circuitry, transformer magnetizing circuitry, cooling fan, air conditioner, lights, computers, server, and lighting. During the daytime, generated yield will provide auxiliary power, whereas during the night-time or downtime, power will be sourced from the grid.

## 2.5.5 Operational workforce

The Project's operational workforce will include a full-time workforce of 16 personnel. Uzbekistan nationals will constitute at least 70% of the operational workforce. In addition, a total of 20-25 specialist staff may be deployed for major maintenance activities.

NOMAC Maintenance Energy Services is the main O&M Contractor appointed for O&M support under the Project Company.

## 2.6 Project Milestones

The Project is currently at the detailed design phase, which includes the completion of engineering designs, acquisition of various permits from competent authorities, and access to project financing.

Table 2-6 below provides an overview of the tentative schedule for subsequent stages of project implementation.

**Table 2-6 Project implementation schedule**

PROJECT FACILITY	START OF LNTP/ EARLY WORKS	START OF NTP/ FULL-ON CONSTRUCTION WORKS	START OF COMMERCIAL OPERATION
<b>100 MW PV plant</b>	January, 2025	September, 2025	June 2026
<b>400 MW PV plant</b>	January, 2025	September, 2025	June, 2027
<b>Nurobod BESS</b>	January, 2025	September, 2025	June, 2027
<b>4.9-km OHTL</b>	August, 2025	September, 2025	April, 2026
<b>70-km OHTL</b>	August, 2025	September, 2025	December, 2026
<b>11-km and 13-km LILO OHTLs</b>	October/ November, 2025 (TBC)	October/ November, 2025 (TBC)	April, 2026

## 2.7 Sazagan Power Purchase Scheme

The Project will be undertaken in parallel with a similar project, namely the Samarkand II Solar PV and BESS Project. Both Projects will be delivered by the Developer, under comparable

agreements with the Ministry of Energy of Uzbekistan. A standalone ESIA has been commissioned for the Samarkand II solar PV and BESS project.

The composite maps below provide an overview of the adjacent facilities and sites planned under these projects.

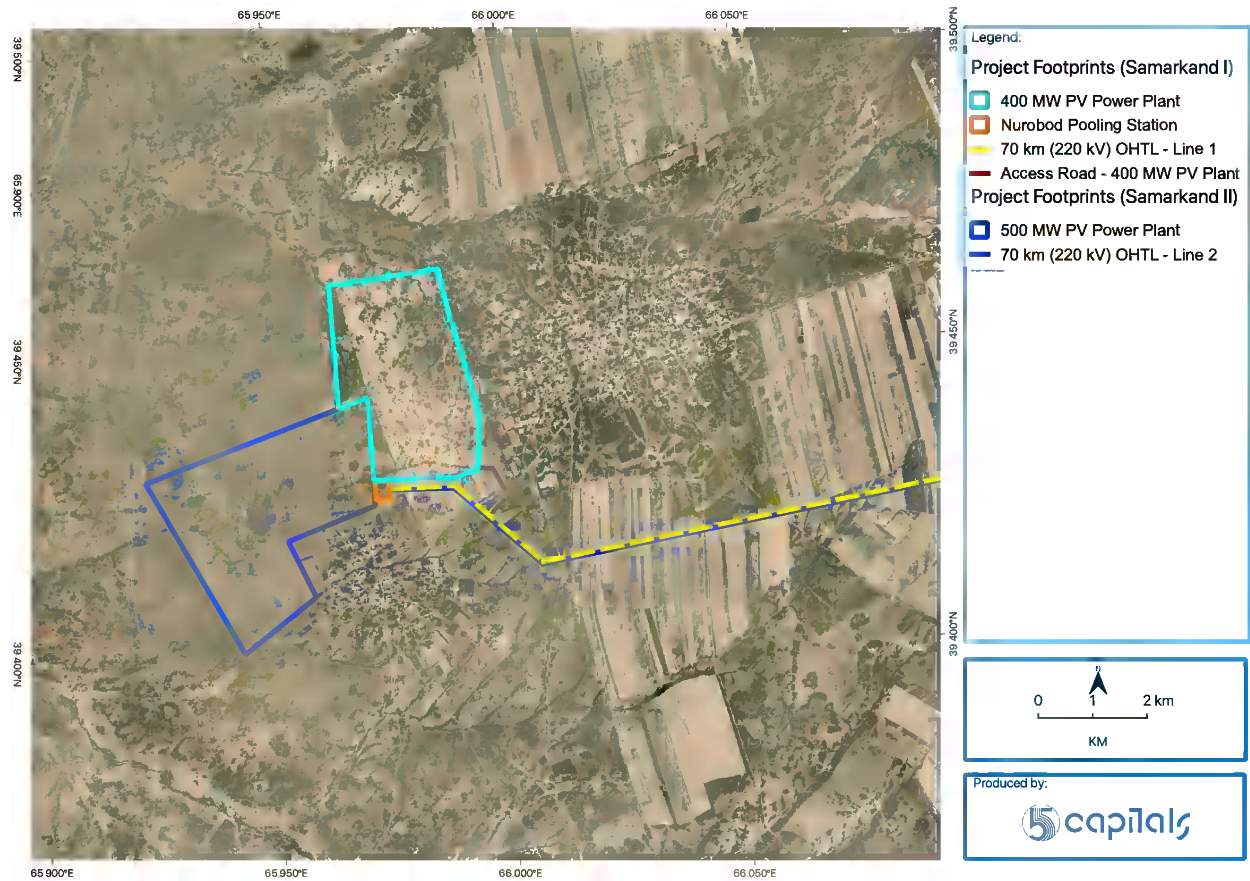

**Figure 2-9 Adjacent, planned power generation and transmission facilities constituting the Project and the associated Samarkand II Solar PV and BESS Project.**

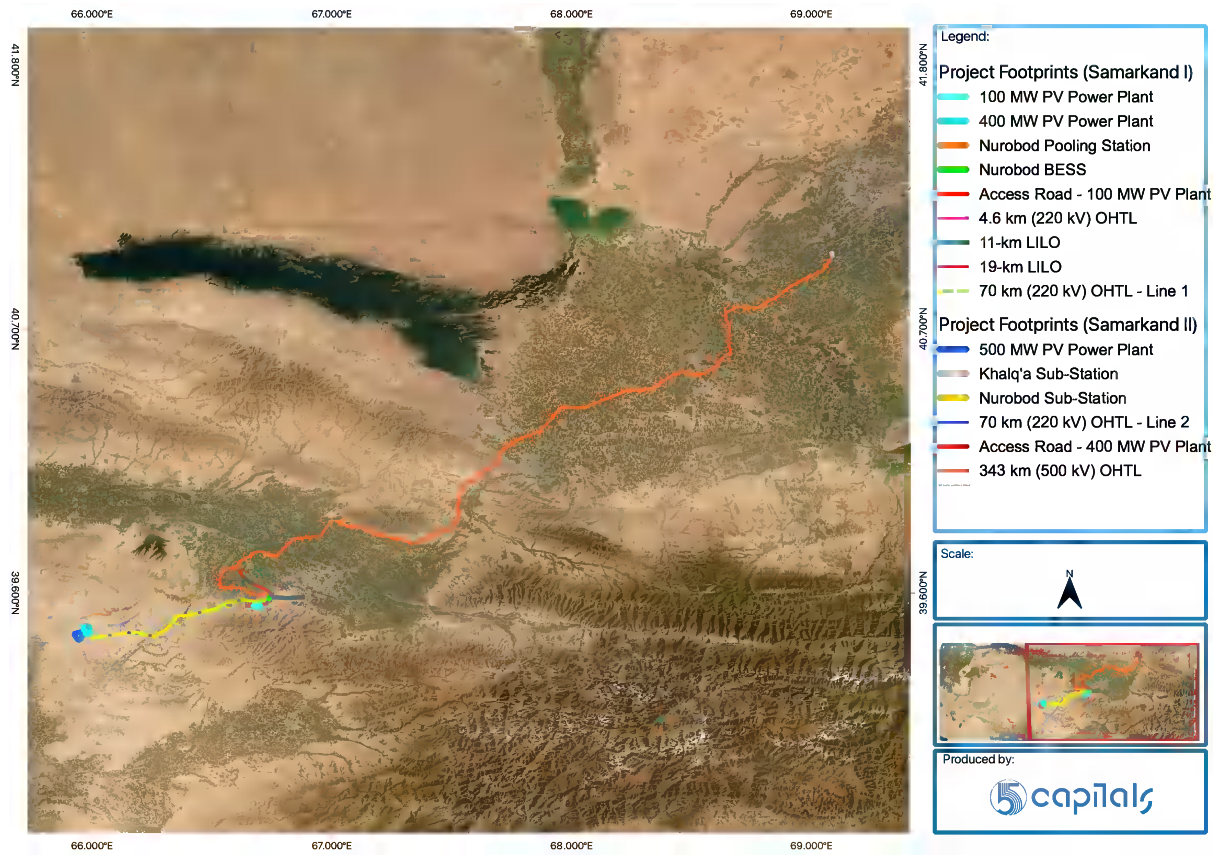

**Figure 2-10 Adjacent, planned power generation, storage and transmission facilities constituting the Project and the associated Samarkand II Solar PV and BESS**

## 3 LAND-USE CONTEXT AND KEY E&S RECEPTORS

### 3.1 Existing Land-Use and Land Acquisition

At present, the majority of the project sites fall within land tracts zoned for agricultural land-use. The Project's land acquisition process will involve the reallocation of the land for industrial use. The best available estimates for the Project's itemized land-take are summarized in the table below. The land areas indicated include both permanent footprints and temporary footprints in the Project's operational and construction phases respectively.

**Table 3-1 Land take for planned project facilities**

SN	PROJECT SITE	AREA (HA)	
		TEMPORARY (CONSTRUCTION FOOTPRINT)	PERMANENT (O&M FOOTPRINT)
1.	100 MW PV power plant	216	216
2.	100 MW PV power plant access road	0.05	0.05
3.	400 MW PV power plant	800	800
4.	400 MW PV power plant access road	0.42	0.42
5.	Nurobod BESS	16.8	16.8
6.	Nurobod BESS underground cable	0.04	0.0
7.	Pooling station	8.5	8.5
8.	4.9-km (220 KV) OHTL	24.8	0.3
9.	70-km (220 kV) OHTL	376.8	3.6
10.	11-km (220 kV) LILO OHTLs	132.4	1.4
1.	13-km (220 kV) LILO OHTLs	114.4	1.4
<b>Total</b>		<b>1690.2</b>	<b>1048.5</b>

#### 3.1.1 100 MW PV Power Plant

The 100 MW PV power plant site is located within a rural area in Nurobod District, which lies about 30 kilometres south-east of the Nurobod district centre, and 18 kilometres south-west of Samarkand City. Land-use includes small-scale crop farming and livestock rearing. No residential buildings were identified within the site, however several agricultural structures, including a livestock pen were enumerated within the plot. Land-use in the vicinity of the site is largely similar, with the presence of crop farms and livestock pens.



**Figure 3-1 Land use within the 100 MW PV plant site**

### 3.1.2 400 MW PV power plant

The 400 MW PV power plant site lies within a rural area in Nurobod District, which lies about 31 kilometres south-west of the Nurobod district centre, and 79 kilometres south-west of Samarkand City.

Land use within the site is predominantly pastoral. Residential property is not present within the site. Land-use in the surrounding vicinity includes small-scale crop farming, and two residential communities.



**Figure 3-2 Dry steppe and scrubland within the 400 MW PV plant site**

### 3.1.3 Pooling station

The pooling station site is located next to the 400 MW PV power plant site, in Nurobod District. Land use within the pooling station is largely similar to that within the PV power plant site, with the absence of any residential property.

### 3.1.4 Nurobod BESS and underground cable

The BESS site is located within a rural area in Pastdargom district, which lies about 8 kilometres south of the town of Juma (district centre), 37 kilometres east of the Nurobod district centre, and 13 kilometres south-west of Samarkand City. Land within the BESS and underground cable perimeter consists of idle fallowland, with limited seasonal grazing activity. No built assets are present within the site. Land-use in the vicinity of the site relatively varied, with herding, livestock farms, crop farms and quarry sites located within a one-kilometre radius.



**Figure 3-3 Denuded, arid landscape within the Nurabad BESS site**

### 3.1.5 70-km and 4.9-km OHTLs

The 70-km and 4.9-km OHTL routes cut across a rural, agricultural landscape in Nurobod District. Land-use in and around the OHTL corridor largely includes crop farming. No residential property was identified within the OHTL corridors.



**Figure 3-4 Pastural land-use and crop cultivation around the 70-km OHTL corridor**

### 3.1.6 11-km and 13-km LILO OHTLs

The 11-km and 13-km LILO (OHTL) routes cut across an agricultural landscape in Pastdargom District, and a small portion of the 11-km (easterly) LILO extends into Samarkand District. Land-use in and around the OHTL corridor is dominated by the cultivation of crops, mainly fruit trees. Several residential clusters are located along the northern end of the 13-km LILO corridor in pastfargom District, and along the southern end of the 11-km LILO in Samarkand District.

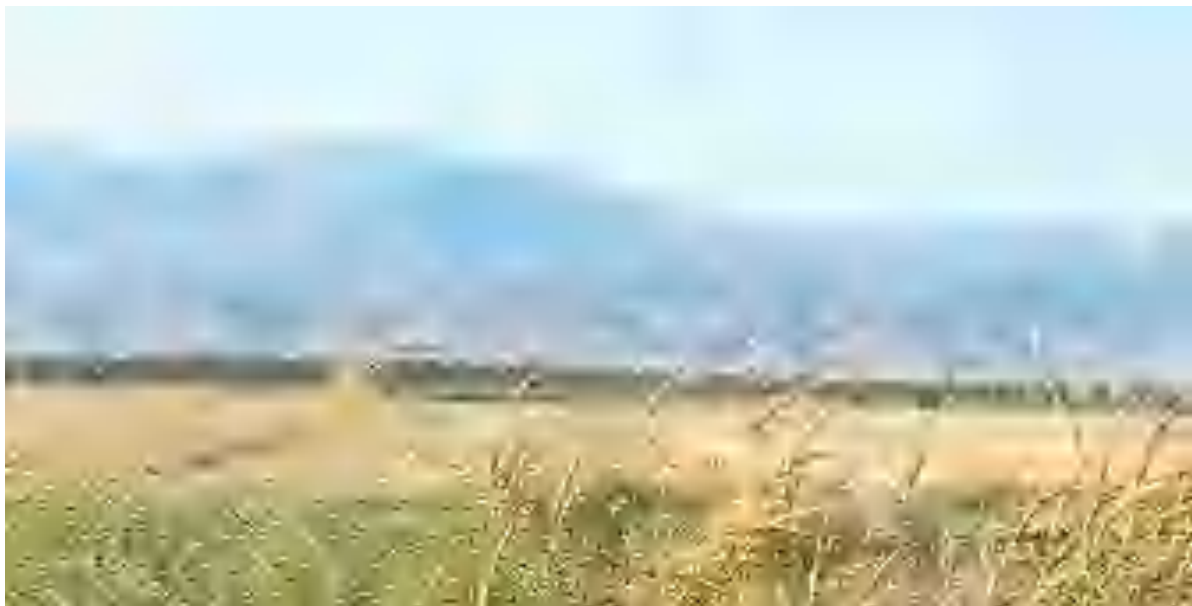

**Figure 3-5 Wheat fields along the 11-km OHTL corridor**

### 3.2 Initial Identification of E&S Impact Receptors

The following maps and tables provide an overview of the E&S impact receptors pre-identified within the Aol, for the Project's non-linear facilities (with the exception of access roads). A receptor map is not provided for the planned OHTLs, considering the multitude of receptors linked to the extensive footprint of these facilities.

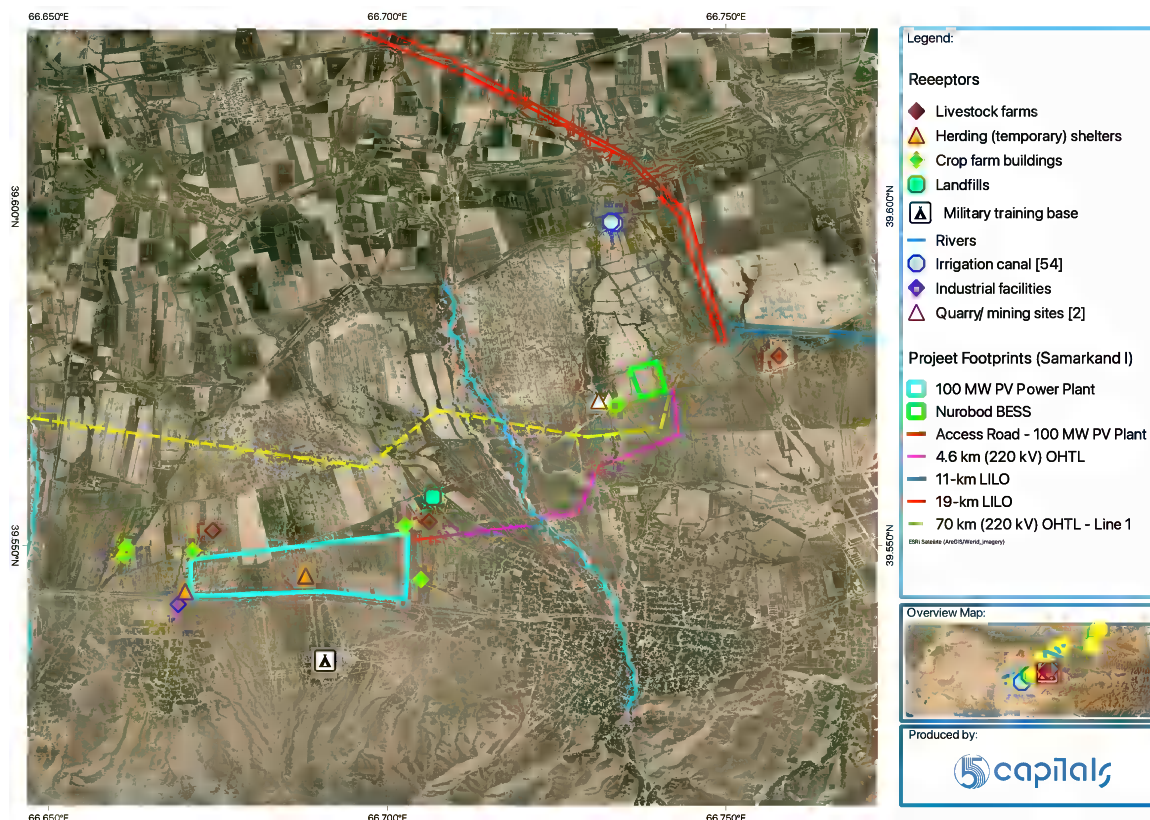

**Figure 3-6 Overview of potential E&S impact receptors within the Aol of the Project's main facilities**

Table 3-2 below provides a list of the E&S receptors provisionally identified within the general preliminary Aol of the 100 MW PV power plant and Nurobod BESS, with respective summary descriptions.

**Table 3-2 Overview of potential E&S impact receptors within one kilometre of the 100 MW PV power plant and Nurobod BESS**

RECEPTOR TYPE	PROXIMITY TO PROJECT SITES	DESCRIPTION
Residential building	140 m	Residential building located North of the 100 MW PV power plant site.
Crop farm buildings/ herding structures	60 – 860 m	Agricultural structures located nearby the 100 MW PV power plant include seasonal herding shelters located West and North-East of the site. A livestock pen is also located within the site.

RECEPTOR TYPE	PROXIMITY TO PROJECT SITES	DESCRIPTION
Livestock farms	165 – 425 m	Chicken farm located East of the Nurobod BESS.
Industrial facility	200 m	Aggregate processing facility located south-west of the power plant site, across the A-378 highway.
Quarry	396 – 530 m	Sand mining sites located west of the Nurobod BESS.
Military base	1.06 km	Military training base located south of the 100 MW power plant site, across the A-378 highway.
Landfill	532 m	Engineered, decommissioned landfill located north-east of the site.
Rivers	2.1 – 2.5 km	Aksai and Sazagansai Rivers located west and east of the 100 MW power plant and Nurobod BESS respectively.

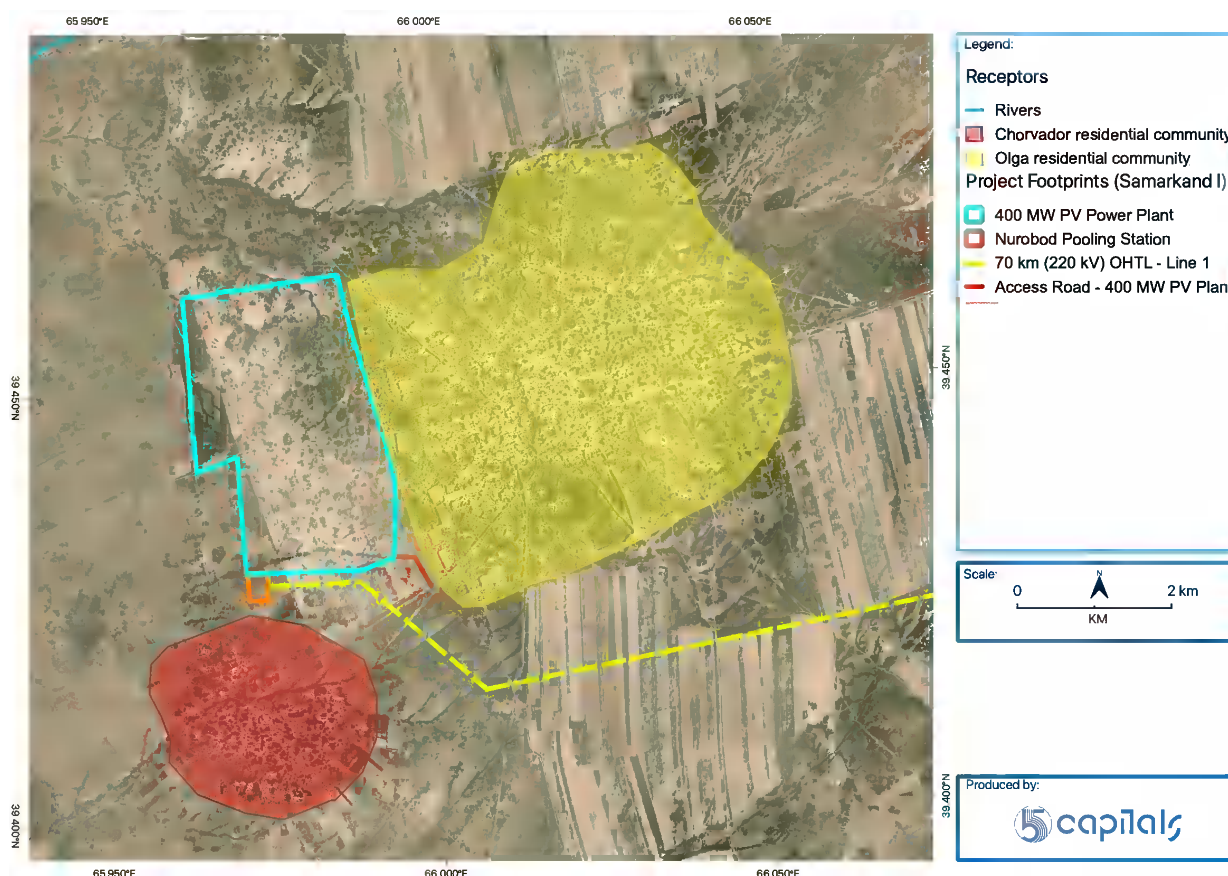
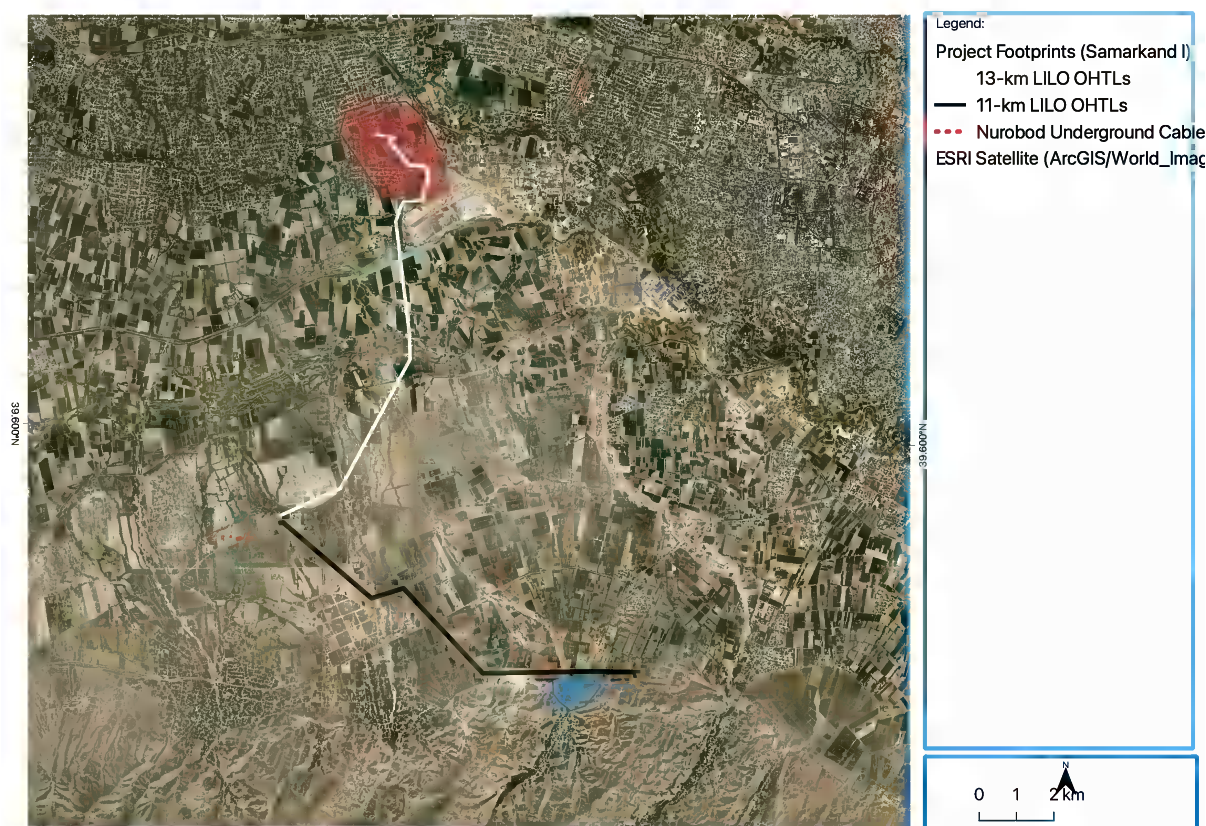

**Figure 3-7 Overview of potential E&S impact receptors within the Aol of the Project's main facilities**

Table 3-3 below provides a list of the E&S receptors provisionally identified within the general preliminary Aol of the 400 MW PV power plant, with respective summary descriptions.

**Table 3-3 Overview of potential E&S impact receptors within one kilometre of the 400 MW PV power plant and pooling station**

RECEPTOR TYPE	PROXIMITY TO PROJECT SITES	DESCRIPTION
Chorvador residential community	600 m	Residential community located east of the 400 MW power plant and pooling station, with the closest dwelling situated about 600 metres from the power plant site boundary.
Olga residential community	50 m	Residential community located east of the 400 MW power plant and pooling station, with the closest dwelling situated about 50 metres east of the PV power plant.



**Figure 3-8 Key E&S receptors along the 11-km and 13-km LILo corridors**

### 3.3 Land Acquisition Process

The Project Developer entered into a PPA with the Ministry of Energy (represented by NEGU JSC) of Uzbekistan in March 2023. On 4th July 2023, a presidential decree was issued to mandate the project plan and its implementation. Amongst other provisions, the presidential decree sets the legal basis for the expropriation of land within specific sites earmarked for the development of the planned project facilities.

The land expropriation process for private-sector projects in Uzbekistan mainly begins with the withdrawal of earmarked land into state reserves, on the basis of a Presidential Decree. Thereafter, project-affected landholders are required to submit voluntary applications for the return of project-affected landholdings to government reserves. Land Allotment Orders (LAOs) are then issued by district- and regional khokimiyats in order to reclassify and reallocate withdrawn land parcels for new land use. The LAO for the Project was issued on 20 July 2023. Afterwards, a Land Lease Agreements is signed by the project developer, the relevant district khokimiyat, and, in this case, the Ministry of Energy of Uzbekistan. The LLA for the PV plant and BESS sites will be signed in June 2025.

The detailed design of the planned OHTLs is underway, and the footprint of the OHTL towers was not fully established at the time of this assessment (i.e., location for pylons along each OHTL).

### 3.4 Analysis of Project Alternatives

At the outset of the Project, literature reviews, field reconnaissance and inter-disciplinary detailed design workshops were carried out to evaluate technical and locational alternatives for the Project. Viable project alternatives presenting minimal E&S risks and impacts, and greater E&S potential benefits were recommended.

In terms of site selection, the location of PV power plant facilities is constrained by factors including solar irradiance, spatial area, compatible land use, climatic (extremes) context, geotechnical and hydrological conditions, grid availability and access. Nevertheless, the final location of the solar power plant infrastructure was guided by early-stage E&S screens, and the proposed routes of the Project's OHTLs were adjusted to avoid key constraints and vulnerable receptors identified at the detailed ESIA stage, such as high-value orchards, intensive farms, residential buildings and clusters, as well as areas of ecological importance.

The 70-km OHTL and 500 MW PV plant sites intersect a critical habitat associated with the Little bustard in Nurobod District. Due to the widespread occurrence of this species across natural grassland and cultivated landscapes within the district, the total avoidance of this expansive habitat was not feasible, in consideration of engineering and regulatory constraints including (but not limited to) regulatory setback from residential communities and unsuitable topography.

## 4 STAKEHOLDER ENGAGEMENT

### 4.1 Stakeholder Engagement Objectives

Stakeholder engagement amongst the key requirements for the conduct of the Project's ESIA, under national law and the Project Lenders' E&S performance standards. According to these instruments, a meaningful and adaptive stakeholder engagement process which begins at reasonably early stages of project planning and continues throughout subsequent stages of project implementation, is intended to fulfil the following E&S performance objectives:

- To establish a participatory, informative and transparent dialogue with parties with the potential to influence the project and/or become affected by the project, as well as constituencies with an interest in the outcome of the project.
- To leverage and integrate local and expert knowledge in the identification and assessment of E&S impacts, subsequent optimization of the project design and effective mitigation planning.
- To establish community buy-in and ensure the delivery of sustainable project benefits to targeted beneficiaries.

Stakeholder engagement is a 'live' process that must be organized by means of a dedicated and documented Stakeholder Engagement Plan (SEP). The SEP developed at the bankable ESIA stage was built upon the rounds of stakeholder engagement discharged as part of the national EIA process. The basis for the preparation of the project SEP and an overview of the SEP commitments are detailed below.

### 4.2 Stakeholder mapping and categorization

The preparation of the Stakeholder Engagement Plan (SEP) commenced with a stakeholder mapping exercise. The wide range of stakeholders associated with the Project were identified and classified based on the review of the Project's legal framework and the preliminary identification of E&S impact receptors by means of desktop research and field reconnaissance. In terms of administrative capacity, the project stakeholders were classified as follows:

1. Project-affected landowners and land users.
2. Project-Affected Communities (PACs).
3. Local Government Authorities ((LGAs) i.e., regional and district administration).
4. National Ministries, Departments, and Agencies (MDAs).
5. Non-Governmental Organizations (NGOs).

6. Project lenders.

### 4.3 Stakeholder Engagement Methods

The modes of stakeholder engagement used at the ESIA stage include formal consultative letters/ correspondence, community meetings, leaflets and infographics, household surveys, Focus Group Discussions (FGDs), Key Informant Interviews (KIIs), participatory site visits, official announcements and media coverage, local and online disclosure of E&S safeguard documents. These consultation and disclosure methods were applied differentially, depending on the stakeholders' relevance to the Project, respective communication agenda, and the progress of engagement.

Following the stakeholder analysis and the selection of suitable engagement modes, a forward Stakeholder Engagement Plan (SEP) was drawn up to ensure that the scope, frequency and differential means of engagement are commensurate with the role and relevance of each stakeholder group.

The above-described modes of stakeholder engagement will continue to be conducted in a manner that is culturally appropriate, understandable to target audiences, and free of manipulation, coercion, and intimidation. The timing and location of community meetings and FGDs were previously organized with efforts to ensure sufficient and equitable representation of groupings or constituencies whose attendance may be constrained by a lack of mobile communication, transportation means and overriding workplace or domestic commitments. Oral and written communication has been made in local languages, namely Uzbek and Russian, as appropriate. All modes of engagement have been documented by minutes of meetings and attendance and/or document dispatch logs, as relevant.

### 4.4 Stakeholder Inputs for ESIA

The stakeholder inputs from various relevant parties are summarized below. Volume II of the ESIA report and the project SEP provide a detailed description of the comments, concerns and feedback raised by the stakeholder groups informed about the Project and consulted over the course of the Project's ESIA process.

- Several Project-Affected Communities (PACs) indicated concerns over electromagnetic radiation and safety of the power plants and OHTL corridors; unemployment rates are generally high in the rural reaches of the project-affected regions, particularly within Nurobod District, and temporary, semi-skilled labour mostly includes agricultural jobs available in the Spring and Autumn seasons; project employment is requested for men and women alike; women can accept semi-skilled project work (i.e., cookery, cleaning, landscaping); communities in

Nurobod District requested for project assistance in revamping local infrastructure such as roads, existing OHTLs, and for entrepreneurial support such as fruit drying facilities for resident women; residents within Nurobod District anticipate access to stable and affordable power supply following the development of the Project, due to long-standing challenges with access to gas (manure from subsistence agriculture is being used for domestic heating etc.) and power outages from dilapidated, overwhelmed power distribution systems; Assistance such as priority credit facilities for women, youth and vulnerable households, as well as social investments to support the establishment of local SMEs (e.g., textile workshops, confectionary factories, agro-processing facilities) would alleviate unemployment and poverty within affected communities; Informal herders in Olga and Chorvador communities requested for livelihood restoration assistance due to extensive loss of grazing land within the 500 MW PV power plant site.

- Various line departments constituting the khokimiyats for the project-affected districts and regions provided miscellaneous information concerning the (pre-project) tenure and utility of land parcels in and around the project sites, progress of land expropriation protocols, as well as information on social services, livelihoods, and general guidance regarding E&S issues.
- The MEEPCC provided technical conditions as part of the positive conclusion on the Stage I national EIA reports.
- Asia Trans Gaz, Uztransgaz and Hududgaz provided information on operational gas pipelines present nearby the project sites.
- The Committee for Public Health prescribed a Health Protection Zone (HPZ) of 50 metres for the PV plant and BESS sites, where residential facilities and occupied workplaces must not be established in the future.
- The Cultural Heritage Agency and Institute of Archaeology provided a statement to indicate the outcome of pre-construction archaeological survey for construction within project sites in Samarkand Region. These authorities also provided a directive requiring a watching brief (i.e., technical supervision) for earthworks during construction.
- The Ministry of Mining and Geology provided information regarding mining and prospecting areas in Nurobod District, and applicable exclusion zones/ setbacks in relation to the 70-km OHTL.
- Focal experts from key wildlife conservation NGOs such as the International Union for Conservation of Nature (IUCN), Eurasian Bustard Alliance (EBA), and Bankwatch provided technical input on potentially suitable and important habitats and population trends for vulnerable avian species, including the Great bustard, Little bustard and Asian houbara. The panel of experts also offered recommendations with regard to effective and actionable offsets, subject to continued dialogue with implementing agencies, such as the Ministry of Ecology, Environmental Protection and Climate Change (MEEPCC) and the Ministry of Energy of Uzbekistan.

## 4.5 Forward Stakeholder Engagement

Forward stakeholder engagement will include disclosure and consultation for E&S safeguard documents (e.g., project ESIA and Land Acquisition and Livelihood Restoration Plan (LALRP)) within the project-affected communities in the districts of Nurobod, Pastdargom and Samarkand. This round of disclosure and consultation will include bilateral meetings with project-affected entities subject to the loss of access to land and related livelihood impacts, to present the LALRP entitlements which will be appended to compensation and livelihood restoration agreements. The purpose of this disclosure is to incorporate any final rounds of feedback from the affected communities and PAPs into the E&S documents, and to notify these stakeholders about the current project plan, potential E&S impacts established at this stage, and relevant mitigation commitments.

Subsequent, regular engagement will be carried out by the Project Company and EPC Contractor local teams to update affected communities about the schedule and scope of construction activities, to familiarize residents with the risks and safeguards related to construction operations (including emergency procedures), and to resolve any grievances raised in relation to construction activities. Stakeholders such as district-level khokimiyats and Uztranzgas will also be engaged for technical guidance and oversight in relation to the avoidance of utility infrastructure during construction works, groundwater abstraction, offset measures for significant impacts on critical and priority habitats, and the management of cultural heritage chance finds. These engagements, as well as those planned for the Project's O&M phase are detailed in the project Stakeholder Engagement Plan (SEP).

## 4.6 Grievance Redress Mechanism

In accordance with lender-prescribed E&S requirements in IFC PS 1, an external GRM has been developed, to enable the timely identification and resolution of grievances and concerns from project stakeholders and the project-affected communities. Local communities based around the project sites have been familiarized with the Project's community GRM to enable the collection of grievances on platforms that are accessible to all constituencies and free of manipulation, interference, intimidation, service charges and restrictions on arbitration, judicial recourse, and choice of confidentiality.

The GRM will allow for the delivery of oral and/or written grievance by aggrieved entities. Reporting channels for external grievances will include:

- Phone calls.
- Email correspondence.

- General consultation forums (i.e., KIs, FGDs, wider community meetings).
- During construction and operations, grievance boxes at project site entry points.
- During construction and operations, submission of grievance forms through in-person meetings with project CLOs or security personnel<sup>2</sup>.

**Table 4-1 Grievance management process, actors and timeline**

ACTION	TIMELINE	RESPONSIBLE PARTIES
Grievance is received/submitted.	-	As relevant: <ul style="list-style-type: none"> <li>• EPC Contractor CLOs</li> <li>• Project Company CLOs</li> </ul>
<ul style="list-style-type: none"> <li>• Grievance is logged.</li> <li>• The grievant is contacted for acknowledgement of receipt and the response timeline is confirmed.</li> </ul>	Within 7 working days of grievance being submitted	As relevant: <ul style="list-style-type: none"> <li>• EPC Contractor CLOs</li> <li>• Project Company CLOs</li> </ul>
<ul style="list-style-type: none"> <li>• Grievance is investigated by the Consultant and Project Company's CLOs.</li> <li>• A decision on remedial action is made.</li> </ul>	Within 14 working days of grievance being submitted*	As relevant: <ul style="list-style-type: none"> <li>• EPC Contractor CLOs</li> <li>• EPC Contractor Social Manager</li> <li>• Relevant EPC Contractor Department Manager</li> </ul> As relevant: <ul style="list-style-type: none"> <li>• Project Company CLOs</li> <li>• Project Company Social Manager</li> <li>• Relevant Project Company Department Manager</li> </ul>
<ul style="list-style-type: none"> <li>• Proposed remedial action or due clarification is conveyed to grievant.</li> </ul>	Within 14 working days of grievance being submitted	As relevant: <ul style="list-style-type: none"> <li>• EPC Contractor CLOs</li> <li>• Project Company CLOs</li> </ul>

<sup>2</sup> Security personnel will receive the necessary induction for handling community grievances and assisting the completion of grievance forms (upon grievants' request).

ACTION	TIMELINE	RESPONSIBLE PARTIES
<ul style="list-style-type: none"> <li>Grievant is requested to provide feedback regarding the remedial action or clarification.</li> </ul> <p><b>Note:</b> The course of action below will be taken in the event that the grievant is not satisfied with the first response.</p>		
<p><b>The following procedures will be followed in the event of negative feedback on first remedial response</b></p>		
<ul style="list-style-type: none"> <li>The grievant's feedback is recorded on the grievance register (i.e., reason for dissatisfaction).</li> <li>If the grievant has a request for an alternative solution, this request is noted as part of the feedback.</li> </ul>	<p>Within 14 working days of grievance being submitted</p>	<p>As relevant:</p> <ul style="list-style-type: none"> <li>EPC Contractor CLOs</li> <li>Project Company CLOs</li> </ul>
<ul style="list-style-type: none"> <li>The grievance is revisited by the Project Company's E&amp;S Manager.</li> <li>New proposed remedial action or final decision with additional clarification/ substantiation is internally prepared.</li> </ul>	<p>Within 28 working days of grievance being submitted</p>	<p>As relevant:</p> <ul style="list-style-type: none"> <li>EPC Contractor CLOs</li> <li>EPC Contractor Social Manager</li> <li>EPC Contractor E&amp;S Manager</li> <li>Relevant EPC Contractor Department Manager</li> </ul> <p>As relevant:</p> <ul style="list-style-type: none"> <li>Project Company CLOs</li> <li>Project Company Social Manager</li> <li>Project Company E&amp;S Manager</li> <li>Relevant Project Company Department Manager</li> </ul>
<ul style="list-style-type: none"> <li>A new proposed solution or final decision with additional clarification/ substantiation conveyed to the grievant.</li> </ul> <p><b>Note:</b> The course of action below will be taken in the event that the grievant is not satisfied with the second response.</p>	<p>Within 28 working days of grievance being submitted</p>	<p>As relevant:</p> <ul style="list-style-type: none"> <li>EPC Contractor Social Manager and CLO</li> <li>Project Company Social Manager and CLO</li> </ul>

ACTION	TIMELINE	RESPONSIBLE PARTIES
<b>The following procedures will be followed in the event of negative feedback on second remedial response</b>		
The grievance and relevant investigation reports are submitted to the LALRP Steering Committee for review.	Within 30 working days of grievance being submitted	As relevant: <ul style="list-style-type: none"> <li>• EPC Contractor CLO</li> <li>• Project Company CLO</li> </ul>
A consensus on the proposed solution.	Within 40 working days of grievance being submitted	As relevant: <ul style="list-style-type: none"> <li>• EPC Contractor CLOs</li> <li>• EPC Contractor Social Manager</li> <li>• EPC Contractor E&amp;S Manager</li> <li>• Relevant EPC Contractor Department Manager</li> </ul> As relevant: <ul style="list-style-type: none"> <li>• Project Company CLOs</li> <li>• Project Company Social Manager</li> <li>• Project Company E&amp;S Manager</li> <li>• Relevant Project Company Department Manager</li> </ul> Other members of the LALRP Committee, including: <ul style="list-style-type: none"> <li>• District khokimiyat representatives</li> <li>• Affected makhalla leader(s)</li> <li>• Designated PAP representatives</li> </ul>
Final decision is conveyed to grievant on concerted remedial measures.  <b>Note:</b> The course of action below will be taken in the event that the grievant is not satisfied with the third response.	Within 40 working days of grievance being submitted	<ul style="list-style-type: none"> <li>• Project Company Social Manager</li> <li>• LALRP Committee Chairperson</li> </ul>
<b>The following procedures will be followed in the event of negative feedback on third remedial response</b>		
1. The grievant is informed about their liberty to pursue alternative recourse for the resolution of the outstanding	-	<ul style="list-style-type: none"> <li>• Project Company Social Manager</li> </ul>

ACTION	TIMELINE	RESPONSIBLE PARTIES
grievance or claim (e.g., court of law), outside of the project organization.		
<p>*In the event that certain complexities result in protracted investigation and remedies, the Grievant will be informed of this delay and advised on the updated timeline to response.</p>		

## 5 SUMMARY OF ENVIRONMENTAL AND SOCIAL IMPACTS

### 5.1 Geology, Soils and Hydrology

#### BASELINE CONDITIONS

A geotechnical survey of the 100 MW PV power plant and BESS sites in Nurobod District revealed that the local geology largely comprises of quaternary sediments, with soil types including sandy and silty loam soils, as well as gravelly sand. Geotechnical investigation on the 400 MW PV power plant site in Nurobod indicates that the local geology largely comprises of quaternary deposits, with resident soils dominated by clayey silts. The surveys concluded that shallow foundations, as well as drainage and stabilization measures are required for construction on all three sites.

Sheet, rill, and gully erosion were not evident within the PV power plant and BESS sites in Nurobod, given the even topography and absence of well-defined drainage channels within these locations. Sites prone to soil erosion were identified along the 70-km OHTL corridor, mainly within farm plots found along rivers, streams and unlined irrigation channels. Precautionary soil sampling within the sites confirmed good to moderate levels of soil quality within the project sites in Nurobod and Pstdargom Districts, and elevated levels of certain heavy metals (e.g., Chromium and Nickel) are attributable to the local geology.

Hydrological surveys within the main project sites in Nurobod and Pstdargom districts confirmed the absence of permanent wetlands in the arid plain landscapes, and shallow aquifers were not encountered up to 10 metres below ground level. Feasibility reconnaissance and ESIA-stage ground-truthing established that the 70-km OHTL crosses two rivers, four streams and one irrigation canal. Flood risk modelling showed that none of the sites are prone to pluvial and alluvial flooding.

#### POTENTIAL IMPACTS – CONSTRUCTION PHASE

Potential impacts on geology, soils and hydrology in the Project's construction phase include soil erosion resulting from various earth-moving activities as well the contamination of resident soil, groundwater, and surface water, due to littering and accidental spills and leakages of materials from construction machinery, equipment and storage facilities, including fuels, lubricants, used oils, paints, solvents, and sewage. Potential soil erosion, sediment loading, and contamination of ambient surface water nearby irrigation canals, streams and rivers along the OHTL footprint may have a negative impact on the aquatic ecology, and in extreme events

(i.e., large chemical spills or sewage ingress), pose a human health hazard. Soil erosion within any construction zones within riverine flood plains can also result in significant erosion and land degradation, while soil contamination within temporary construction areas can degrade arable land. Nevertheless, these impacts are largely restricted to the OHTL corridor, with moderate potential significance, considering the limited extent of construction works for project OHTLs and micro-siting efforts for OHTL pylons. The contingent establishment of boreholes on the 500 MW PV plant site and any intensive periods of water abstraction for construction use can also result in drawdown and groundwater stress, which could extend to existing community wells within 100-200 metres of the site.

#### **POTENTIAL IMPACTS – OPERATION PHASE**

The risk of contamination of resident soil, groundwater, and surface water within the project sites and undesignated dump sites, extends into the Project's O&M phase, due to littering and accidental spills and leakages of materials, including fuels, lubricants, used oils and sewage from O&M machinery, plants and storage facilities, and leaching from electronic refuse.

#### **IMPACT AVOIDANCE AND MITIGATION MEASURES**

Provided the avoidance and mitigation measures specified in the C-ESMP and O-ESMP are implemented, the significance of the above-mentioned potential impacts will be reduced to a minor status. General mitigation requirements involve the isolation of hazardous materials (including waste) within specialized storage facilities, and controlled excavation and stockpiling of soil to minimize the displacement of soil. Detailed hydrological surveys and a water demand assessment will be completed to establish whether groundwater abstraction permitting conditions for the establishment of on-site boreholes can be met. Any occurrences of accidental spills onto ambient soil or water will be address using excavation and spill kits, as appropriate, and drip trays will be used for leaking equipment requiring off-site maintenance. Site rehabilitation will be undertaken following the completion of construction works to remove on-site waste and re-establish the soil profile with appropriate fertilization and/or seeding efforts to restore the productivity of land outside of the Project's permanent footprint.

An Erosion Control Plan, Water Management Plan, Site Rehabilitation Plan, Waste Management Plan, Hazardous Materials and Waste Management Plan, Occupational Health and Safety Plan, Spill Preparedness and Response Procedure will be developed to manage relevant impacts on geology, soils, and hydrology.

## **5.2 Solid Waste and Wastewater**

### **BASELINE CONDITIONS**

For the main (PV power plant and BESS) project sites, the nearest available facilities for the treatment and disposal of solid waste from the Project's construction and operational phases include Kylichli and Sazagan landfills in Samarkand Region. Facilities available for the treatment and disposal of project wastewater include the Main Samarkand, Geofizika, and Farhad Wastewater Treatment Plants (WWTPs) in Samarkand Region.

#### **POTENTIAL IMPACTS – CONSTRUCTION PHASE**

Potential impacts related to waste and wastewater in the Project's construction phase include (i) contamination of resident soil, groundwater, and surface water, due to littering and accidental spills and leakages of materials from construction machinery, equipment, and storage facilities and concrete washout disposal, (ii) adverse impacts on human health resulting from contamination of ambient soil and water and/ or direct exposure to hazardous construction waste (including medical waste), (iii) degradation of air quality due to offensive odours from putrescible construction waste streams, (iv) as well as increased pressure on local waste management facilities.

#### **POTENTIAL IMPACTS – OPERATION PHASE**

Potential adverse impacts on ambient soil, water, and human health from the generation of waste, extends into the Project's operational phase, due to accidental spills and leakages of materials, including fuels, lubricants, used oils and sewage from O&M machinery, plants and storage facilities, and leaching from electronic refuse. At the decommissioning stage, the uninstallation and disassembly of O&M facilities will generate substantial amounts of end-of-life waste, such as spent PV panels, batteries, and other electronic refuse. Some of this waste can be categorized as hazardous waste requiring special transportation and disposal safeguards.

#### **IMPACT AVOIDANCE AND MITIGATION MEASURES**

Provided the avoidance and mitigation measures specified in the C-ESMP and O-ESMP are implemented, the significance of the above-mentioned potential impacts will be reduced to a minor status. General mitigation requirements involve the isolation of hazardous and soluble materials (including waste) within specialized storage facilities, the engagement of licensed waste collection and management contractors for waste management services and monitoring to ensure that all hazardous waste streams generated by the project are delivered to engineered landfills, industrial wastewater treatment plants, and any other specialized facilities (e.g., incinerators) for the safe and sanitary management of such waste. Concrete wash-out pits of an adequate capacity will be constructed within the PV plant and sub-station sites to treat concrete washout water, and sanitation facilities such as chemical (portable)

toilets, toilets and washrooms with underground septic tanks will be installed for containment and appropriate disposal of sewage. Although decommissioning is not anticipated to occur during the term of the Project Developer's PPA for the Project, the Project Company and O&M Company will develop a Waste and Hazardous Materials Management Plan, which will include recommendations for the management of end-of-life waste at the Project's decommissioning stage.

A dedicated Water Management Plan, Waste Management Plan and Hazardous Materials and Waste Management Plan will be developed to manage impacts related to the generation of waste and wastewater.

## 5.3 Terrestrial and Aquatic Ecology

### BASELINE CONDITIONS

The baseline conditions relating to terrestrial and aquatic ecology in and around the project sites were defined by means of specialized baseline surveys for various taxa (including literature review, field studies and stakeholder consultation), and a simultaneous Critical Habitat Assessment (CHA) study aimed at identifying habitats of conservation concern.

#### 5.3.1 Flora and habitat types

Two rounds of botanical surveys were undertaken in the summer/autumn (July-September) season of 2023 and the Spring (April) season of 2024. To analyse vegetation structure and species composition, 46 geo-botanical sample plots (SPs) of 50x50 metres were strategically sited and surveyed within homogenous habitat types identified in and around each project site. The survey strategy was based on a round of literature reviews and full-scale field reconnaissance. The summary findings for each project location are listed below:

- 100 MW PV power plant site – Four habitat types identified within the site include arable land, fallow land, fruit gardens and vineyards, and dry grasslands. A total of 70 species were recorded, none of which have a threatened conservation status on the national and global red lists.
- 400 MW PV power plant site – Two habitat types identified within the site include fallow land and dry grassland. A total of 40 species were recorded, none of which have a threatened conservation status on the national and global red lists. The total extent of natural habitat (with 0.5 score) extrapolated for the site amounts to 194 hectares, while the remaining 605 hectares is modified habitat (with 0.3 score).
- 4.9-km OHTL corridor – Four habitat types identified along the corridor include arable land, fallow land, dry grasslands, and dry beds of temporary streams. A host of floral species were recorded, none of which have a threatened conservation status on the national and global red lists.

- 70-km OHTL corridor – Six habitat types identified along the corridor include arable land, fallow land, fruit gardens and vineyards, boundary strips, roadsides, canals and drainage channels, dry grasslands and dry beds of temporary streams. A total of 76 of floral species were recorded, none of which have a threatened conservation status on the national and global red lists.
- BESS site – Two habitat types identified within the site include fallow land and dry grassland. A total of 29 species were recorded, none of which have a threatened conservation status on the national and global red lists.
- 11-km LILO OHTL corridor – Five habitat types identified along the corridor include gravelly-clay plains, dry beds of temporary streams, agricultural fields, fallow land and sandy (quarry) sites. A total of 35 species were recorded, none of which have a threatened conservation status on the national and global red lists.
- 13-km LILO OHTL corridor – Three habitat types identified along the corridor include dry bed of temporary streams, fallow land and boundary strips. A total of 55 species were recorded, none of which have a threatened conservation status on the national and global red lists.

### 5.3.2 Herptiles

Two rounds of herptile (reptile and amphibian) surveys were undertaken in the summer/autumn (July-September) season of 2023 and the Spring (April) season of 2024. The primary approach for field research involved a combination of stationary and transect surveys, which involve the enumeration of individuals along a predetermined path, or transect, extending up to 2 km in length. The summary findings for each project location are listed below:

- 100 MW PV power plant – A total of 3 herptile species were recorded, namely Steppe agama (*Trapelus sanguinolentus*), Rapid Racerunner (*Eremias volex*), and the Asian Snake-eyed Skink (*Ablepharus pannonicus*). In sum, 28 Central Asian tortoise individuals were identified, which indicates significant resident population/ density. None of the species are classed as threatened on the IUCN red-list and Redbook of Uzbekistan.
- 400 MW PV power plant – A total of 5 herptile species were recorded, namely Steppe agama (*Trapelus sanguinolentus*), Rapid Racerunner (*Eremias volex*), Sunwatcher Toad-headed Agama (*Phrynocephalus helioscopus*), and the Central Asian tortoise (*Testudo horsfieldii*). A total of 28 Central Asian tortoise individuals were identified, which indicates a notable population/ density.
- 4.9-km OHTL corridor – A total of 3 herptile species were recorded, namely Steppe Agama (*Trapelus sanguinolentus*), Rapid Racerunner (*Eremias volex*), and the Central Asian tortoise (*Testudo horsfieldii*). Only one Central Asian tortoise individual was identified, which indicates a very small resident population/ density.
- 70-km OHTL corridor – A total of 3 herptile species were confirmed to occur in the area, namely Steppe Agama (*Trapelus sanguinolentus*), Rapid Racerunner (*Eremias volex*), and the Central Asian tortoise (*Testudo horsfieldii*). Only one

Central Asian tortoise individual was identified, which indicates a very small resident population/ density.

- Nurobod BESS – A total of 3 herptile species were recorded. Of these, only the Central Asian tortoise has a threatened (VU) status on the IUCN red-list and the Redbook of Uzbekistan, however only one individual was identified, which indicates a very small resident population/ density.
- 11-km and 13-km LILO OHTL corridor – No herptile species were recorded during the survey period.

A follow-up round of herptile surveys was scheduled for May-June 2025, to ascertain the absence of any nocturnal species within areas of natural habitat identified after the Spring 2024 botanical survey and subsequent habitat quality assessment.

As the Central Asian tortoise is a globally and nationally threatened species which has triggered a Priority Biodiversity Feature (PBF) habitat within the Project's Aol, a dedicated offset plan will be developed further as part of the Biodiversity Action Plan (BAP), to ensure a No Net Loss (NNL) conservation outcome for the species.

### 5.3.3 Non-volant mammals

The mammalian baseline surveys were carried out in the summer/ autumn season (June-September 2023) within each project site. The surveys primarily involved strategically sited transects and plots, however camera traps were also deployed on the PV power plant and BESS sites in Nurobod District. The summary findings for each project location are listed below:

- 100 MW PV power plant – Direct observations and indirect indicators (i.e., tracks and burrows) showed the presence of 9 mammalian species within the site. Of these, only the Corsac fox (*Vulpes corsac*) and Steppe polecat (*Mustela eversmanni*) are classed as VU in the Redbook of Uzbekistan.
- 400 MW PV power plant – Direct observations and indirect indicators (i.e., tracks and burrows) showed the presence of 5 mammalian species within the site. None of the species are classed as threatened, with the exception of the Corsac fox (*Vulpes corsac*), which is classed as VU in the Redbook of Uzbekistan.
- 70-km OHTL corridor – Direct observations and indirect indicators (i.e., tracks and burrows) showed the presence of 14 mammalian species within the site. None of the species are classed as threatened, with the exception of the marbled polecat which is classed as VU in the Redbook of Uzbekistan.
- BESS – Direct observations and indirect indicators (i.e., tracks and burrows) suggest the presence of 6 mammalian species within the site, namely long-eared hedgehog (*Hemiechinus auratus*), yellow ground squirrel (*Spermophilus fulvus*), zaisan mole vole (*Ellobius tancrei*), red fox (*Vulpes vulpes*), steppe polecat (*Mustela eversmanni*), asiatic wildcat (*Felis silvestris ornate*). None of the species are classed as threatened on the IUCN red-list and Redbook of Uzbekistan, with

the exception of the steppe polecat which is classed as VU in the Redbook of Uzbekistan.

- 11-km and 13-km OHTL corridors – Four and five species recorded respectively.

#### 5.3.4 Bats

Bat roost searches were carried out for potentially resident bat species in the Spring season (April) of 2024, within all of the project sites. Follow-up surveys involving the capture of acoustic bat calls were carried out subsequently in the PV power plant and sub-station sites, where the presence of bats was considered highly likely. Bat groupings identified within these sites include a total of six species, none of which are of conservation concern globally and within Uzbekistan.

- 100 MW PV power plant – *Eptesicus sp. (serotinus+ognevi)*, *Myotis sp.*, and *Pipistrellus pipistrellus*.
- 400 MW PV power plant – *Eptesicus sp. (serotinus+ ognevii)*, and *Tadarida teniotis*.
- BESS – *Eptesicus sp. (serotinus or ognevii)*, *Myotis sp.*, and *Pipistrellus pipistrellus*.

#### 5.3.5 Avifauna

In addition to literature reviews, bird surveys undertaken within the project sites and corridors include (i) Vantage Point (VP) surveys targeting migrant bird species in the Autumn (September – November) of 2023 and Spring (February – April) of 2024, at 19 VP locations; Asian houbara point-count surveys in and around the PV plant and sub-station sites in Spring (April) of 2024; Winter bird survey (Great bustard and Little bustard) transects and point counts in the Winter season (January – February) of 2024, within all project sites and the 70-km corridor in particular; and raptor nest searches along the OHTL corridors in the Spring (April – May) season of 2024. An additional round of Spring-time VP surveys and raptor nest survey was arranged between 21 April and June, 2025. The purpose of this survey is to provide a better (site-specific) coverage of raptor migration, foraging and breeding activity along the final layout of the LILo routes. The results of this survey, follow-up assessment and any adaptive management measures will be provided in the next (updated) version of this ESIA.

A total of four globally threatened avian species were recorded over the course of the baseline surveys, which include the Egyptian vulture, steppe eagle, eastern imperial eagle, and the great bustard. A total of eight (8) threatened avian species trigger PBF habitats within the Project's Aol. In addition, over 2,000 Little bustard individuals were sighted within the critical habitat along the 70-km OHTL and 400 MW PV plant Aol corridors in Nurobod.

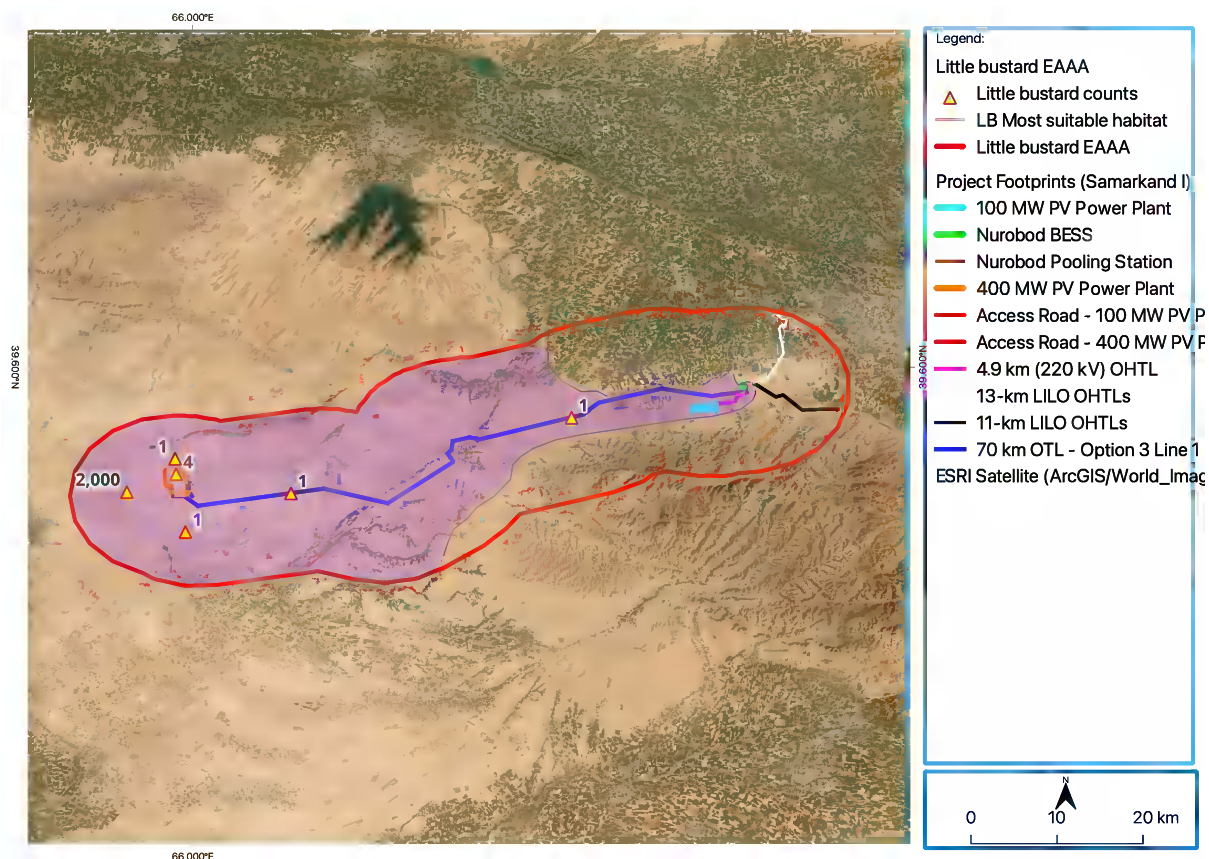

**Figure 5-1 Little Bustard EAAA/ critical habitat in relation to the Project's AoI and section of the EAAA with the highest number of Little Bustard observations**

The congregation was observed within Mubarek State Wildlife Sanctuary, 4.6 km West of the 400 MW PV power plant. According to ADB SPS guidance, this Category IV protected area therefore qualifies as an additional area of critical habitat. However, the Project will impact on a limited portion of this Little bustard critical habitat, which overlaps with the Project's Area of Influence (AoI) and EAAA for the species.

### 5.3.6 Aquatic ecology

Baseline surveys on the aquatic ecology context of the project sites and corridors were limited to literature review and stakeholder consultations. Primary data collection was not undertaken considering the absence of the project footprint (i.e., sites and activities) within wetlands including rivers, streams and large irrigation canals. Nevertheless, the Critical Habitat Assessment (CHA) conducted as part of the ESIA covered local aquatic biodiversity. The CHA uncovered three globally and nationally threatened fish species potentially resident in wetlands within 50 km of the project areas, namely the *Luciobarbus brachycephalus* (Aral

Barbel), *Luciobarbus conocephalus* (Turkestan Barbel), and the *Cyprinus carpio* (Eurasian Carp).

#### **POTENTIAL IMPACTS – CONSTRUCTION PHASE**

Potential impacts on biodiversity in the Project's construction phase include habitat loss, direct mortality, take (i.e., poaching, hunting, and gathering), displacement/ dispersal, introduction of invasive and alien species, as well as habitat degradation and displacement due to soil, water, air, noise, and light pollution from various construction activities.

#### **POTENTIAL IMPACTS – OPERATION PHASE**

Potential impacts on biodiversity in the Project's operation phase include bird and bat mortalities from 'lake effect' (i.e., collision with PV panels mistaken for water bodies), habitat fragmentation due to permanent fencing and edge effects, which may collectively contribute to the species reduced foraging, reproductive success, and survivorship within the project sites. Potentially significant impacts of note include avian mortality due to habitat loss, fatal collisions, and electrocution associated with the OHTL superstructures.

#### **IMPACT AVOIDANCE, MITIGATION AND OFFSET MEASURES**

Provided the avoidance and mitigation measures specified in the C-ESMP and O-ESMP (and supplementary biodiversity management plans) are implemented, the significance of the above-mentioned potential impacts will be reduced to a negligible to minor status. The main preventative and mitigation requirements at the construction stage include micro-siting of project facilities to avoid important habitats (i.e., riparian habitats), the restriction of construction works and site clearance to delineated construction zones, observation of protective buffers for river, stream and canal sections nearby project sites, prohibition of hunting, poaching and harvesting and the uncontrolled use of herbicides and pesticides, restriction of speed for project vehicles, implementation of a Biodiversity Chance Find Procedure, various measures for abating water, soil, noise, air and light pollution, as well as site inspections to identify any establishment of invasive floral species.

Dedicated mitigation and offset measures to ensure No Net Loss (NNL) for the 194 hectares of natural habitat identified within the 400 MW PV plant site will be developed. In total, 225 Central Asian tortoises were translocated from the 400 MW PV plant site (and an adjacent project site) and released in a recipient natural habitat located 2 kilometres North of the site during the active season (i.e., May/early June 2024). Additional measures to ensure No Net Loss (NNL) include the construction of a ring fence with openings/ conduits for the return of tortoises onto restored, on-site natural habitat, following construction.

Bird flight diverters (either FireFly brand or a similar brand with a long-term guarantee against failure) will be installed on OHTL sections to increase line visibility by thickening the appearance of the line by a minimum of 20 cm over a length of 10-20 cm. The diverters will be moveable, of contrasting colours (e.g., black and white), and placed 5-10 m apart and be placed along OHTL sections until such a point that a diverter experiment from another project undertaken by the Project Developer may provide evidence to demonstrate that either a different type of line marker should be installed or that neither type of marker or diverter is sufficiently effective to warrant installation (e.g., effectiveness <10%). The BFDs will be installed along the entire stretch of the project OHTL corridors, with the exception of OHTL sections in town areas.

Additional NNL safeguards to mitigate and offset significant impacts on vulnerable avifauna with PBF habitats also include the commitment to a raptor-safe OHTL tower (cross-arm) design for all project powerlines, and the staggered arrangement of project OHTL towers, relative to the position of OHTL towers along existing (non-project) OHTLs, habitat restoration after the completion of construction activities and the implementation of a Post Construction Fatality Monitoring (PCFM) Program. Any PBF raptor fatalities identified over the course of the PCFM program will be assessed against species-specific fatality (take) thresholds established in the Potential Biological Removal (PBR) analysis report prepared alongside the project ESIA and Biodiversity Action Plan (BAP).

The contingent offset plan to ensure conservation Net Gain (NG) for the little bustard will prioritize the (i) removal or full-on decommissioning of existing (non-project) OHTLs in disuse, or (ii) undergrounding of operational, non-project OHTLs within the critical habitat. In the event that the above priority measures are proven unviable, interventions such as the creation of a Little bustard reserve, implementation of measures to reduce illegal poaching of Little bustards, and agro-ecological enhancements to Little bustard wintering/migratory stopover habitats, will be explored and implemented.

The Biodiversity Action Plan, Biodiversity Management Plan (BMP), Biodiversity Monitoring and Evaluation Program (BMEP) and Biodiversity Chance Find Procedure (BCFP) will be developed further to guide coordinated management of impacts on biodiversity, as well as regular monitoring to ensure the success of related safeguards and adaptive management. In addition, a PCFM Program will be undertaken with independent oversight, for a period of at least three years, in keeping with the IFC-EBRD-KfW Good Practice Handbook.

## 5.4 Noise and Vibration

### BASELINE CONDITIONS

One noise monitoring location was established at a noise-sensitive (residential) receptor nearest to the 100 MW PV plant site, two noise monitoring locations were sited at sensitive (residential) establishments nearby the 400 MW PV power plants site, and one monitoring location was sited at a potentially sensitive (workplace) receptor nearby the BESS site. Baseline ambient noise monitoring was undertaken using a calibrated Class 1 noise level meter mounted 1.7 metres above ground level. The survey was set to cover both working and weekend days, and the analysis of the measurements accounted for daytime (7 am to 11 pm) and night-time noise levels (11 pm and 7 am). A-weighted noise level measurements were made over continuous 24-hour durations and noise level data was logged at 10-minute intervals.

Based on average results for LA90, which is the best indicator for ambient noise (environmental) noise, noise levels within the vicinity of the PV plant and BESS sites mostly range from 31 dB(A) to 44 dB(A), for 90% of the daytime. In general, daytime levels of ambient noise (in terms of LAeq) are well within both local and international limits for residential and commercial/ industrial zones. Qualitative noise surveys along the lengthy OHTL corridors indicate low ambient noise levels, with the exception of locations nearby railways and highways.

### POTENTIAL IMPACTS – CONSTRUCTION PHASE

Potential impacts on noise-sensitive establishments in the Project's construction phase include elevated levels of ambient noise, elevated levels of ambient ground borne vibration, and occupational exposure to noise and vibration.

Construction noise will arise from noise-generating activities including the pile driving, offloading of materials and equipment, movement of construction vehicles, and the operation of other construction machinery (e.g., excavators, compactors etc.). Construction vibration is expected to occur as a result of land clearing, grading, excavation, rock-breaking, compaction and pile driving. Different levels of ground borne vibration emanate from heavy construction machinery, such as bulldozers, excavators, graders, vibratory rollers, drill rigs, cranes, and Heavy Goods Vehicles (HGVs).

### POTENTIAL IMPACTS – OPERATION PHASE

Potential impacts on noise-sensitive establishments in the Project's operation phase include elevated levels of ambient noise, and occupational exposure to noise and vibration. At this stage, substantially lower noise emissions will arise from the operation of numerous and high-

voltage electrical equipment. For the PV power plants, these emissions potentially comprise low-frequency, humming noise from constituent inverters and medium-to-high voltage transformers. For the BESS plant, operational noise emissions will likewise be generated by the array of inverters and transformers, as well as the high-capacity Heating, Ventilation and Air Conditioning (HVAC) system, however, no significant influences will impact on nearby noise receptors based on the results of operational noise modelling. The movement of vehicles for transportation of O&M workers and transfer of materials and equipment for maintenance purposes may influence ambient noise levels.

#### **IMPACT AVOIDANCE AND MITIGATION MEASURES**

Provided the avoidance and mitigation measures specified in the C-ESMP and O-ESMP are implemented, the significance of the above-mentioned potential impacts will be reduced to a minor status. General mitigation requirements during construction include the location of noise- and vibration-generating machinery as far as possible from receptors within 500 metres' distance, use of noise shielding and mufflers, as well as minimizing simultaneous use of machinery and/or noise-generating activities. Mitigation in the Project's operational stage include the use of similar measures, particularly equipment enclosure and acoustic barriers such as a site fences, and the implementation O&M programs for various operational equipment.

## **5.5 Air Quality**

#### **BASELINE CONDITIONS**

To evaluate pre-project levels of ambient air quality, one air quality monitoring location was selected at a sensitive receptor, which is a residential establishment nearest to the 500 MW PV power plant site. Another air quality monitoring location was selected nearby a potentially sensitive receptor neighbouring the BESS site. For areas of influence around in and around the 100 MW PV power plant site and the OHTL corridors, a qualitative survey was completed, considering the absence of significant, ongoing, air quality influences (i.e., point and diffuse pollution sources) and proximate sensitive receptors in these areas, as well as substantially lower potential emissions from OHTL-related construction and O&M activities.

Baseline ambient air quality monitoring was undertaken using a calibrated air quality monitor (AQ Mesh), equipped with an anemometer. Air quality measurements were taken over a continuous 24-hour duration and data for air quality parameters was logged at 15-minute intervals.

Average results for all air quality parameters measured near the PV power plant and sub-station fall within national and WHO 24-hour guideline limits for air pollutants including particulate matter. The analysis also indicates that pre-project ambient concentrations of particulate matter (i.e., PM<sub>2.5</sub> and PM<sub>10</sub>) meet the WHO guideline thresholds for this category of air pollutants, with the exception of the averaged PM<sub>10</sub> results for the 400 MW PV power plant site.

#### **POTENTIAL IMPACTS – CONSTRUCTION PHASE**

Potential impacts relating to air quality in the Project's construction phase include elevated levels of ambient dust, elevated levels of ambient exhaust pollutants, and occupational exposure to air pollutants. The generation of airborne dust will arise from site preparation activities and earthworks, including land clearance, excavation, grading, stockpiling, loading and off-loading of aggregates and circulation of construction vehicles. The emission of exhaust fumes is also expected to occur due to the operation of various construction machinery, including earthworks equipment and Heavy Goods Vehicles (HGVs).

#### **POTENTIAL IMPACTS – OPERATION PHASE**

Impacts on ambient air quality are not expected to occur in the Project's operational phase and have therefore been scoped out of the assessment.

#### **IMPACT AVOIDANCE AND MITIGATION MEASURES**

Provided the avoidance and mitigation measures specified in the C-ESMP are implemented, the significance of the above-mentioned potential impacts will be reduced to a minor status. General mitigation requirements during construction include damping down of dust roads and working areas (commensurate with wind conditions), speed restrictions for HGVs, controlled and sheltered unloading of aggregates with fine particulates, minimizing the usage of fuel powered machinery, implementation of O&M programs for various machinery, proper storage of construction materials containing Volatile Organic Compounds (VOCs) and appropriate storage and handling of putrescible domestic waste and wastewater.

## **5.6 Landscape and Visual Amenity**

### **BASELINE CONDITIONS**

The 100 MW PV plant site landscape and its 1-kilometre sweep is characterized by fallow land, pockets of cultivated land and patches of dry grassland. No significant, natural landscape elements, such as natural vegetation reserves, pristine grassland or wetlands are present within the landscape, with the exception of a scenic mountainous area located 3km south of the

site. The 400 MW PV plant site falls within an expanse of sparse, dry grassland, with two residential settlements located immediately East and South of the site. The landscape in and around the BESS is characterized by generally flat terrain with little to no vegetative cover, a mountainous area located 3 km South of the site, and a few farm buildings located immediately East and West of the site.

#### **POTENTIAL IMPACTS – CONSTRUCTION PHASE**

Potential impacts on the landscape within affected viewsheds include the loss of visual amenity due to alteration of landscape character due to vegetation clearance, earthworks, and establishment of temporary obstructive structures and features (e.g., construction structures/ plants, vehicles etc.), as well as light spills from night-time movement of project vehicles and site illumination. Due to the absence of landscape elements of high aesthetic value and the relatively flat terrain in and around the project sites, potential visual nuisances/ intrusions from construction activities are expected to be minor to moderate.

#### **POTENTIAL IMPACTS – OPERATION PHASE**

Potential impacts in and around the PV power plant, BESS, and OHTL sites include the loss of visual amenity due to alteration of landscapes of scenic value resulting from land conversion and the establishment of permanent structures (e.g. new fencing, OHTL towers and conductors). The establishment of the PV plant site will also result in glint and glare impacts due to the reflection of light from the PV modules, which may cause distraction and eye irritation. Visual impacts from new OHTLs have been minimized at the design stage through routing new lines as parallel as possible to other planned and existing OHTLs.

#### **IMPACT AVOIDANCE AND MITIGATION MEASURES**

Provided the avoidance and mitigation measures specified in the C-ESMP, Site Rehabilitation Plan and O-ESMP are implemented, the significance of the above-mentioned potential impacts will be reduced to a minor status. General mitigation requirements during construction include inward orientation and shielding of any on-site floodlights, and the implementation of site rehabilitation post construction demobilization. Mitigation measures during operations include the use of fitting, inconspicuous paintwork on prominent structures and vegetative screens around prominent/ protruding structures, to the extent feasible.

## 5.7 Traffic and Transportation

### BASELINE CONDITIONS

Chinese-sourced project freight will be moved along Asian Highway 5 (AH5) up to Uzbekistan. From the border village of Jibek Joly in Kazakhstan, the M39 highway will be used for transit towards Samarkand City. The total length of the project traffic corridor from the Kazakhstan border point to the project sites in Nurobod and Pastdargom districts ranges from 380 to 460 km. A planned 70-metre access road will connect the A-378 highway to the 100 MW PV power plant site while an existing, 5-km long feeder road connecting the A-378 highway to Pastdargom District will provide access to the BESS site. The transportation route towards the 400 MW PV power plant includes the 4P52 feeder road branching out of the A-378 highway, a smaller municipal road, and a planned 696-metre access road.

Rapid traffic counts along highways and municipal roads connected to the project access roads indicate low to moderate traffic volumes. The highest counts (i.e., 386 vehicles per hour) counts were recorded along the A-378 highway around 5.30 pm.

### POTENTIAL IMPACTS – CONSTRUCTION PHASE

Potential impacts relating to traffic and transportation during construction include increased traffic congestion along public roads within the Project's transit corridor and access roads, due to the movement of project vehicles for the transportation of construction materials, equipment, and workers. Increases traffic congestion and increased travel times resulting from project traffic can disrupt local transportation patterns, impede timely access to workplaces and other key destinations, cause economic losses and present an inconvenience to road users.

### POTENTIAL IMPACTS – OPERATION PHASE

Impacts on traffic and transportation are not expected to occur in the Project's operational phase and have therefore been scoped out of the assessment.

### IMPACT AVOIDANCE AND MITIGATION MEASURES

Provided the avoidance and mitigation measures specified in the C-ESMP and Traffic and Transportation Management Plan are implemented, the significance of the above-mentioned potential impacts will be reduced to a minor status. General mitigation requirements during construction include the development of dedicated access roads connecting to the project sites, use of traffic signage, personnel, and suitable bypasses to control vehicular traffic in the event of project-related upgrading works on existing roads, use of dedicated parking bays,

and the minimization of vehicular traffic by optimizing logistics and collective staff commutes, as well as the avoidance of peak traffic hours.

## 5.8 Cultural Heritage

### BASELINE CONDITIONS

The archaeological sites and historic monuments protected within Samarkand Region include the ruins of the ancient Afrisiyab Town, Registan Ensemble, Shah-i-Zinda Ensemble with a collection of mausoleums, Bibi-Khanyim Mosque, Gur-e-Amir Mausoleum and Ulugh Bey Observatory, and silk road sites including the Jartepa II Temple, Suleimantepa and Kfirkala Settlement.

The Cultural Heritage Agency and Institute of Archaeology commissioned an independent pre-construction archaeological survey to ensure the absence of significant, undiscovered cultural resources within the project sites. The expert surveys concluded that no critical or non-replicable cultural heritage resources were encountered within the footprint of the PV power plant, BESS, and OHTL sites.

### POTENTIAL IMPACTS – CONSTRUCTION PHASE

Potential impacts relating to cultural heritage during construction include the degradation and/ or loss of existing (protected) and potential (undiscovered) tangible cultural heritage resources due to earthworks, compaction, drilling, the movement of heavy construction machinery, as well as off-roading and trespassing incidents in and around the project sites.

The Project's construction phase may also entail the disruption of local customs and intangible cultural heritage as a result of the influx of a considerably large migrant workforce into the Project's host communities, erosion of local cultural values and possible tension and conflicts arising out of cultural fissures between the migrant project labour and local community members.

### POTENTIAL IMPACTS – OPERATION PHASE

Impacts on cultural heritage are not expected to occur in the Project's operational phase and have therefore been scoped out of the assessment.

### IMPACT AVOIDANCE AND MITIGATION MEASURES

Provided the avoidance and mitigation measures specified in the C-ESMP and Archaeological Chance Finds Procedure are implemented, the significance of the above-mentioned potential impacts will be reduced to a minor status. The key mitigation requirements during construction include the prohibition of construction works outside of demarcated sites and

working areas, observation of protective buffers around existing archaeological and historical sites nearby the project area, implementation of the archaeological watching brief (supervision) for earthworks within any areas of interest identified by the Institute of Archaeology. The risk of social tensions from the disruption of local customs will also be managed through the establishment of dedicated accommodation facilities for project workers and compulsory worker trainings in the Project's Code of Conduct, respect for local customs.

## 5.9 Socioeconomics

### BASELINE CONDITIONS

Administratively, the project footprint falls within Samarkand Region, the districts of Nurobod, Pastdargom and Samarkand, and 20 affected communities (makhallas). A detailed, ESIA-oriented socioeconomic study comprising literature reviews, site walkovers, KIIs, FGDs and household-level surveys was undertaken within the project-affected communities and districts between 23rd September 2023 and 17 January 2024.

The economy of Nurobod District is centred on agriculture, specifically rainfed crop farming and animal rearing. Low agricultural productivity in the district is attributed to the absence of irrigation canals, declining rainfall, and the saline condition of resident soils. The economy of Pastdargom district is largely based on agriculture, however, the northern part of the district is located closer to the rivers of Zarafshan and Dargom, with more extensive irrigated agriculture. Please refer to Volume II (Main Text) of the ESIA report, for information regarding the local demography and access to social services within the project-affected districts and communities. Summary information on existing land-use within the project sites, and the land acquisition process is presented in Section 3 document.

The ethnic profile of the project-affected communities and their respective districts is almost exclusively Uzbek, with ethnic minorities including Tajik, Turkmen, Kyrgyz, Kazakh, Russian, Korean, Tartar and gypsies. A review of the national policies and legislation of Uzbekistan, literature survey and consultation with the community development departments of the district- and regional khokimiyats, as well as consultations with expert representative from resident Cultural Heritage Agency confirmed that no indigenous or insular minorities exist within the project-affected districts.

### POTENTIAL IMPACTS – CONSTRUCTION PHASE

Potential impacts relating to livelihoods and social services in the Project's construction phase include economic displacement due to land expropriation and temporary land access

restrictions during construction, accidental damage to public property and utility service interruptions, increased pressure on public infrastructure and resources, transient inflation within host communities, as well as employment creation and capacity transfer.

LALRP-stage surveys established that project-related land acquisition will result in the economic displacement of 203 entities, which represent a total of 904 Project-Affected Persons (PAPs). These entities include 178 Project-Affected Households (PAHs), seven (7) Project-Affected Businesses (PABs), and 18 governmental institutions (including certain utilities). Of the 203 land-users enumerated, 189 are affected landholders (titled and non-titled) and 14 are affected workers hired by impacted landholders. No instances of physical displacement have been recorded within the Project's footprint. Overall, a total of 48 Project-Affected Households (PAHs) were identified as vulnerable. The majority of PAPs are crop farmers, who are subject to temporary farming restrictions (land access) during construction (along the OHTLs). Project-affected persons subject to permanent land-take and related income losses mainly include livestock farmers and informal herders based around the PV power plant and BESS sites in Nurobod District.

The Social Compliance Audit (SCA) held between March and May 2025 confirmed that a total of 20 land users (including titled crop farmers, titled livestock farmers, non-titled herders and farm workers) were prematurely displaced from the 100 MW PV plant and BESS sites between July 2023 and March 2025. The early onset of economic displacement (i.e., withdrawal from land used prior to the Project) was attributed to the progress of land expropriation protocols<sup>3</sup> and the commencement of unidentified site investigation work prior to the start of LNTP activities.

Elaborate information regarding livelihood impacts associated with the land expropriation is presented in the Land Acquisition and Livelihood Restoration Plan (LALRP) developed in parallel with the project ESIA. The Plan describes the extent of land-take for project-affected households, businesses and other entities, and elaborates on the compensation and other livelihood restoration support measures for different affected entities, with different tenure modes for project-affected land parcels.

---

<sup>3</sup> Submission of voluntary applications for the return of project-affected landholdings to Government reserves and subsequent issuance of the Land Allotment Order.

## POTENTIAL IMPACTS – OPERATION PHASE

The Project will contribute to the national (installed) power production capacity and associated economic growth throughout its operational lifetime.

### IMPACT AVOIDANCE AND MITIGATION MEASURES

Provided the avoidance and mitigation measures specified in the C-ESMP are implemented, the significance of the above-mentioned potential impacts will be reduced to a minor status, with the exception of economic displacement, which carries minor to moderate significance. The key supplementary plans that will be implemented for the management of impacts on local livelihoods and social services include the Land Acquisition and Livelihood Restoration Plan (LALRP), Local Content Plan, Influx Management Plan, Water Management Plan, and Traffic and Transportation Management Plan.

At the outset of the ESIA and subsequent LALRP studies, efforts to minimize the extent of involuntary resettlement included the relocation of the 400 MW PV plant within Nurobod District to avoid residential property, and the adjustment of the 70-km to avoid residential assets and high-value agricultural property, to the extent feasible. The LALRP includes safeguards to ensure effective relocation and income restoration, such that the pre-project income earning capacity and living standards are not rendered worse off. These measures include the provision of compensation at full replacement value (according to DFI eligibility criteria), monetary and non-monetary livelihood restoration measures for transitional support, and continual monitoring to validate the adequacy of pre-planned livelihood restoration support streams. In addition, all 20 PAHs and PABs who incurred early displacement between July 2023 and March 2025 will receive additional compensation and livelihood restoration support, based on detailed household-level consultation and a retrospective assessment of premature displacement impacts.

The LARLP finalisation and implementation will be a participative process, which will involve (i) consultation with project-affected entities prior to implementation, (ii) establishment of a LALRP Steering Committee with representatives from Project-Affected Households (PAHs), and (iii) development of a specific SEP.

## 5.10 Community Health, Safety and Security

### BASELINE CONDITIONS

With regards to morbidity within the nine project-affected communities, the ESIA-stage socioeconomic survey (including a total of 157 households) revealed that the most common diseases within the communities include acute respiratory infections and cardiovascular

conditions. Despite a limited availability of advanced healthcare centres in some parts of the country and a variable shortage of medical practitioners, survey results indicate that 90% of surveyed households within the project-affected communities have access to medical facilities within a 700 metres' distance. Please refer to Volume II (Main Text) of the ESIA for information regarding water supply, sanitation and waste management facilities within the project affected communities and districts.

Authorities responsible for law enforcement, maintenance of order and investigation of crimes within the host region, districts and makhallas include the local police force, operating under the Ministry of Internal Affairs and the National Security Service. In Uzbekistan, training, planning and emergency response to fire, floods and other disasters is coordinated by the Ministry of Emergency Situations. Several commercial fire response and rescue entities also provide fire emergency services, particularly within urban centres and Tashkent Region.

The cultural context of Uzbekistan is characterized by patriarchal customs, which have historically influenced gender equality in the spheres of education, employment, and national politics. With regard to the prevalence of gender-based human rights violations within the country, various forms of violence, harassment and exploitation have been reported in recent years.

#### **POTENTIAL IMPACTS – CONSTRUCTION PHASE**

Potential impacts relating to community health, safety and security in the Project's construction phase include spread of communicable diseases and increased local morbidity due to the influx of migrant workers (and inter-mingling with local communities), community health and safety incidents resulting from various on-site and off-site construction hazards, as well as the risk of criminal and abusive offences against local community members.

#### **POTENTIAL IMPACTS – OPERATION PHASE**

Potential impacts relating to community health, safety and security in the Project's construction phase include community health and safety incidents (e.g., electrocution accidents, Electromagnetic Field (EMF) hazards, traffic accidents, fire hazards and related accidents).

#### **IMPACT AVOIDANCE AND MITIGATION MEASURES**

Provided the avoidance and mitigation measures specified in the C-ESMP and O-ESMP are implemented, the significance of the above-mentioned potential impacts will be reduced to a minor status. The key supplementary plans that will be implemented for the management of impacts on community health, safety and security include the dedicated Community Health and Safety Plan, Influx Management Plan, Hazardous Materials and Waste Management Plan,

and Emergency Preparedness and Response Plan, during construction, as well as the Hazardous Materials and Waste Management Plan, Community Health and Safety Plan, and Emergency Preparedness and Response Plan, during operations.

## 5.11 Labour Conditions and Occupational Health and Safety

### BASELINE CONDITIONS

The various challenges that beset the labour rights context of Uzbekistan are discussed in Volume II (Main Text) of the ESIA report. A summary of forced labour within the Chinese Xinjiang Ughur Autonomous Region (XUAR) is also provided in Volume II of the report.

### POTENTIAL IMPACTS – CONSTRUCTION PHASE

Potential impacts relating to working conditions and occupational health and safety in the Project's construction phase include unequal access to employment opportunities and benefits due to discriminatory and/or exploitative recruitment practices, poor working and living conditions, occupational health and safety incidents (i.e., various forms of workplace injury, related disabilities and potentially fatal accidents), forced labour, child labour, and workplace harassment, violence and other security incidents involving project workers.

### POTENTIAL IMPACTS – OPERATION PHASE

Potential impacts relating to working conditions and occupational health and safety in the Project's operation phase include unequal access to employment opportunities and benefits due to discriminatory and/or exploitative recruitment practices, occupational health and safety incidents, forced labour, child labour and workplace harassment, violence and other security incidents involving project workers.

### IMPACT AVOIDANCE AND MITIGATION MEASURES

Provided the avoidance and mitigation measures specified in the C-ESMP and O-ESMP are implemented, the significance of the above-mentioned potential impacts will be reduced to a minor status. In relation to the solar supply chain, a bill of materials up to Tier 5 (Metallurgical Grade Silicon ("MGS")) was reviewed by the Project Lenders. Overall, the key supplementary plans that will be implemented for the management of construction-phase impacts on labour conditions and occupational health and safety include a dedicated Local Content Plan, Occupational Health and Safety Plan, Emergency Preparedness and Response Plan, Worker Accommodation Plan and Supply Chain Management Plan, alongside the project-level Human Resource Policy, Human Rights Policy and Code of Conduct. An equivalent set of

management plans and policies will be developed for labour related risks and impacts in the Project's operational phase.

## 5.12 Climate Risks

### BASELINE CONDITIONS

Mean annual air temperatures have risen steadily and significantly in Uzbekistan over the past few decades, with varying rates of increase. Between 1990 and 2020, the country's mean annual temperature grew at a rate of 0.03°C per decade. To understand possible temperature and precipitation extremes within the Project's operational phase, in the high-emissions scenario, climatological projections were performed for the period 2040-2059, based on the Shared Socioeconomic Pathway (SSP) 5 (Fossil Fuel Development), paired with the Representative Concentration Pathway (RCP) 8.5.

in Samarkand Region, the projected rise in average maximum temperature will peak at a median magnitude of 36.2 °C in the month of July, by 2040, which represents a 3°C median jump from the baseline median. Likewise, by 2024, the projected rise in the average largest 1-day precipitation in Samarkand Region will peak at a median magnitude of 34.1 mm, in the month of March, which represents a 6.5 mm median jump from the baseline median.

### CLIMATIC RISKS

The Project is subject to several physical climate risks associated with the projected temperature and precipitation extremes, including reduction in solar module efficiency and yield under high temperatures, reduction in transmission capacity of project OHTLs, thermal runaway and associated fire hazards for the BESS, damage to OHTL infrastructure due to flooding from high-precipitation events, power shortages and socioeconomic losses due to climate-related plant downtime (forced outage), as well as workplace and third-party H&S incidents resulting from climatic extremes and disasters.

A number of avoidance measures have been incorporated into various aspects of the project design (e.g., site selection away from flood prone areas, foundation design and PV module selection), and additional climate-proofing measures for fire safety, lightning protection, HVAC cooling systems for the BESS, and drainage systems are also planned to mitigate climate-related risks to the project infrastructure. In addition, construction- and operation-phase greenhouse gas emissions will be minimized using the Traffic and Transportation Management Plan, and O&M programs for project equipment and vehicles.

## 6 ENVIRONMENTAL AND SOCIAL MANAGEMENT AND MONITORING

The construction-phase and operation-phase ESMS will need to incorporate mitigation and monitoring requirements established in Volume II of the ESIA, as well as any additional requirements prescribed by the Ministry of Ecology, Environmental Protection and Climate Change (MPEECC).

Volume III of the ESIA provides a framework for the development of the Environmental and Social Management System (ESMS) for the construction and operational phases of the Project. The framework has been developed to ensure that all E&S impacts identified for both construction and operational phases are appropriately identified and controlled through the development of a robust construction and operational phase ESMS.

The Project Company will institute ESMS Manuals for both project phases to ensure there is sufficient oversight of the ESMS implementation within the Project Company, EPC and O&M Companies, and their respective primary sub-contractors and suppliers, and to ensure project-wide compliance, E&S risk and opportunity management including monitoring.

The primary documents guiding the environmental and social management of the construction and operational phases will be the construction-phase and operation-phase Environmental and Social Management Plans (C-ESMP, O-ESMP) respective to construction and operational E&S risks, impacts and compliance requirements. Detailed monitoring arrangements and requirements will be presented in the Environmental and Social Monitoring Plan, and other supplementary E&S management plans.

The E&S organization for the Project Company's ESMS implementation will include a dedicated HSSE / E&S Manager, H&S Manager, Social (Resettlement) Manager, as well as Community Liaison Officers (CLOs). For the EPC Contractor, key E&S positions include HR Manager, distinct H&S and E&S Managers, CLOs, ecologists, and other supporting staff commensurate to the number of workers on site for construction phase.

### 6.1 Independent Auditing and Monitoring

The Project will be subject to periodic independent monitoring in accordance with the requirements of the Environmental and Social Action Plan (ESAP) prepared by the Project Lenders. This line of E&S monitoring will focus on the implementation of the project ESMS and evaluate on-site activities, documented E&S impact controls and relevant monitoring efforts, with respect to the Project's compliance obligations.

---

Key monitoring commitments include the mid-term and completion audits for the LALRP implementation, as well as a post-construction fatality monitoring plan for avifauna, which will be implemented over a period of three years.

## APPENDIX A – PROJECT CONTACT INFORMATION

**Table A-1-1 Project Contact Information**

COMPANY	CONTACT DETAILS
<b>Project Company</b>	Name: Yuliya Allakhverdiyeva (E&S Manager) Tel: +998954299920 Email: yallakhverdiyeva@acwapower.com
<b>EPC Contractor</b>	Name: Eslam Hanafy (E&S Manager) Tel: +998909856521 Email: mailto:eslaamhakiem@gmail.com
<b>O&amp;M Company</b>	Name: Alisher Ametov Tel: +998 99 460 5667 Email: alisher.ametov@nomac.com