

# Nukus 200 MW Phase 2 Wind Farm Uzbekistan

Environmental and Social  
Impact Assessment –  
Volume 1

## Non-Technical Summary



April 2025

## DOCUMENT INFORMATION

<b>PROJECT NAME</b>	Nukus 200 MW Phase 2 Wind Farm Uzbekistan
<b>5Cs PROJECT NUMBER</b>	1305/001/156
<b>DOCUMENT TITLE</b>	Environmental & Social Impact Assessment – Volume 1: Non-Technical Summary
<b>CLIENT</b>	ACWA Power
<b>5Cs PROJECT MANAGER</b>	Tarek Tabaja (Senior Consultant)
<b>5Cs DIRECTOR</b>	Ken Wade (Director)

## DOCUMENT CONTROL

VERSION	VERSION DATE	DESCRIPTION	AUTHOR	REVIEWER	APPROVER
1.0	17/01/2025	ESIA NTS	AYY	MKB/UR	KRW
2.0	25/02/2025	Updates following lender comments	MKB	KRW	KRW
3.0	09/04/2025	Updates for Internal OHTL Alignment	MKB	MKB	KRW



1	Financial Capital	Regardless of location, mode of delivery or function, all organisations are dependent on
2	Social Capital	<i>The 5 Capitals of Sustainable Development</i> to enable long term delivery of its products or services.
3	Natural Capital	Sustainability is at the heart of everything that
4	Manufactured Capital	5 Capitals achieves. Wherever we work, we strive to provide our clients with the means to maintain and enhance these stocks of capital assets.
5	Human Capital	

## DISCLAIMER

5 Capitals cannot accept responsibility for the consequences of this document being relied upon by any other party, or being used for any other purpose.  
This document contains confidential information and proprietary intellectual property. It should not be shown to other parties without consent from the party which commissioned it.

This document is issued for the party which commissioned it and for specific purposes connected with the above-identified project only. It should not be relied upon by any other party or used for any other purpose

# CONTENTS

1	WHAT IS THE PROJECT?	1
1.1	Project Overview	1
1.2	Key Project Information	2
1.3	Project Description	2
1.3.1	Project Facilities	3
1.3.2	Shared Facilities	8
1.4	Associated Facilities	10
1.5	Construction Phase Activities and Facilities	10
1.5.1	EPC Contractor	10
1.5.2	LNTP Works	10
1.5.3	Main Construction Activities	11
1.5.4	Temporary Site Facilities	12
1.5.5	Construction Workforce and Accommodation	14
1.5.6	Site Worker Welfare	15
1.6	Project Operation and Maintenance	15
1.6.1	Activities	15
1.6.2	Workforce	15
1.7	Key Project Milestones	16
2	WHERE IS THE PROJECT LOCATED?	17
3	WHAT IS THE CURRENT SITUATION?	21
3.1	Land Ownership	21
3.2	Land Use and Site Conditions	21
3.3	Nearby Communities	24
3.4	Potential Human Receptors	25
3.5	Ecology	28
3.6	Other Local Environmental Influences	29
4	WHAT ARE THE KEY BENEFITS?	31
5	WHAT ARE THE NEGATIVE IMPACTS OR UNCERTAINTIES AND HOW ARE THESE TO BE MANAGED?	33
6	ENVIRONMENTAL AND SOCIAL MANAGEMENT AND MONITORING	40

## APPENDIX A – PROJECT CONTACT INFORMATION

# 1 WHAT IS THE PROJECT?

## 1.1 Project Overview

The Government of the Republic of Uzbekistan (GOU) through the Ministry of Energy aims to increase the electricity production in the country from 12.9 GW in 2019 to 29.3 GW in 2030 in order to foster economic growth as part of the Republic of Uzbekistan (Uzbekistan) 2030 Energy Strategy.

The Uzbekistan 2030 Energy Strategy defines the mid-term and long-term objectives and direction for development in the power sector to ensure electricity supply in Uzbekistan. One of the objectives of the Energy Strategy includes the development and expansion of renewables and their integration into the unified power system.

In regard to the development of wind farms, the Energy Strategy states the following as priority:

*“Creation of large-scale wind farms with single site capacities ranging from 100 MW to 500 MW mostly concentrated in North-Western region (Republic of Karakalpakstan and Navoi region) shall be the main priority of wind power development”*

Of the 29.3 GW of power generating capacity in 2030, 8 GW will be from renewable energy, with wind power accounting for 3 GW.

The Nukus 200 MW Wind Project is a facility contributing towards the 2030 Energy Strategy.

GOU has signed a memorandum of understanding with the European Bank for Reconstruction and Development (EBRD) with a view to cooperate on the development of large-scale wind power projects up to a total capacity of 1,000 MW. As an extension of 100 MW Wind Farm in Qoraozak district (Phase I), the implementation of 200 MW wind farm with a Battery Energy Storage System (BESS) between Beruniy and Qoraozak districts is considered by GOU.

ACWA Power has been awarded the right to design, finance, construct, operate, maintain and (at the request of the Government) decommission or transfer, the Nukus 200 MW Wind Project including the Evacuation Infrastructure (EI) (the Project) in the Karatau mountain region of the Republic of Karakalpakstan.

### **SCOPE OF THE DOCUMENT**

5 Capitals Environmental and Management Consulting (5 Capitals) has been engaged by ACWA Power to undertake certain environmental and social studies during the development process of the Project, including the Environmental and Social Impact Assessment (ESIA) package.

An ESIA is a comprehensive process to identify and assess the environmental and social impacts of a project. It provides an overview of the project's design, construction and operational processes, assesses impacts upon sensitive receptors (e.g. communities, ecology sensitivities) within the project's area of influence and reviews the applicable regulatory and legislative frameworks, including national laws, international standards, and lender requirements.

The ESIA examines existing environmental conditions through baseline surveys, evaluates project alternatives, and identifies mitigation and management measures to minimise adverse impacts and enhance positive outcomes. It also establishes a framework for developing and implementing management plans during the project's construction and operational phases.

This document constitutes the Non-Technical Summary (Volume 1) of the Project's ESIA.

## 1.2 Key Project Information

**Table 1-1 Key Project Information**

<b>PROJECT TITLE</b>	Nukus 200 MW Phase 2 Wind Farm
<b>PROJECT DEVELOPER</b>	ACWA Power
<b>PROJECT COMPANY</b>	"ACWA Power Beruniy" Wind FE LLC
<b>OFF TAKER</b>	JSC National Electric Grid of Uzbekistan
<b>EPC CONTRACTOR</b>	POWERCHINA - SINOHYDRO
<b>O&amp;M COMPANY</b>	NOMAC
<b>ENVIRONMENTAL &amp; SOCIAL CONSULTANT</b>	5 Capitals Environmental and Management Consulting (5 Capitals) PO Box 119899, Dubai, UAE Tel: +971 (0) 4 343 5955, Fax: +971 (0) 4 343 9366 www.5capitals.com
	Juru LLC Chust Str. 10, 100077, Tashkent, Uzbekistan Tel: +998 71 202 0440, Fax: +998 71 2020440
<b>POINT OF CONTACT</b>	Ken Wade (Director), Ken.wade@5capitals.com

## 1.3 Project Description

### WIND ENERGY OVERVIEW

Wind turbines harness the energy of the wind and convert it to electricity. The amount of energy produced by wind turbines increases with wind speed and modern turbines are able to adapt efficiently to extract energy from a range of wind speeds.

Wind speeds typically increase with height above ground as turbulence (due to topography and ground features) intensity decreases. This typically allows turbines with higher hub heights to produce more energy than a turbine with a lower height at the same location. In addition, longer blades (the rotor radius from the turbine) significantly increase the swept area from which wind energy can be extracted.

### 1.3.1 Project Facilities

The Project will have following main components and facilities:

- 26 WTGs
- 220 kV Substation
- Common 220 kV switchyard originally designed and constructed for the Phase 1 project (Nukus 100 MW Wind Farm).
  - **Note:** This was designed to cater for the additional capacity of the Nukus 2 WF Project.
- 100 MWh AC-coupled Battery Energy Storage System (BESS)
- Operations & Maintenance (O&M) building
- Internal road providing access to the WTGs
- OHTL route of approximately 42-44 km in length running from the switchyard to the existing 220/110 kV Beruniy substation. Some modifications in the existing Beruniy substation to tie the OHTL into the grid.

#### WIND TURBINE GENERATORS

The Project consists of 26 Wind Turbine Generators (WTGs), located within the allotted site boundary. The Envision EN 182-8.0MW HH 138m Steel Tower Turbine models has been selected and has the following specification.

**Table 1-2 WTG Details**

<b>WTG MODEL</b>	Envision EN 182-8.0MW HH 138m Steel Tower Turbine
<b>CAPACITY</b>	8 MW
<b>BLADES</b>	3
<b>HUB HEIGHT</b>	138 m
<b>ROTOR DIAMETER</b>	182 m
<b>SWEPT AREA</b>	26,016 m <sup>2</sup>
<b>CUT-IN WIND SPEED</b>	3 m/s
<b>CUT-OUT WIND SPEED</b>	25 m/s
<b>DESIGN LIFETIME</b>	25 years



**Figure 1-1 WTG Appearance (Envision, nd)**

### **BESS**

The Project will involve the establishment of a 100 MWh AC-coupled Battery Energy Storage System (BESS). The BESS facility will serve the following main functions:

- Storage of electrical energy from power sources feeding into the project-associated utility grid during off-peak grid time, and the dispatch of the operating reserves in the event of grid congestion (i.e., instances of power demand exceeding power supply).
- Stabilization of the frequency of the project-associated utility grid by provisioning power reserves to equalize power demand and power supply within the grid.

The BESS facility is designed to address power shortages within the grid connecting to the Wind Farm planned under the Project, to prevent and alleviate the occurrence of power outages within Beruniy District. Power shortages can arise in the event of peak power demands, downtime events of power generation facilities feeding into the grid and declines in the electrical yield of the Wind Farm as a result of wind variability or icing and snow accumulation.

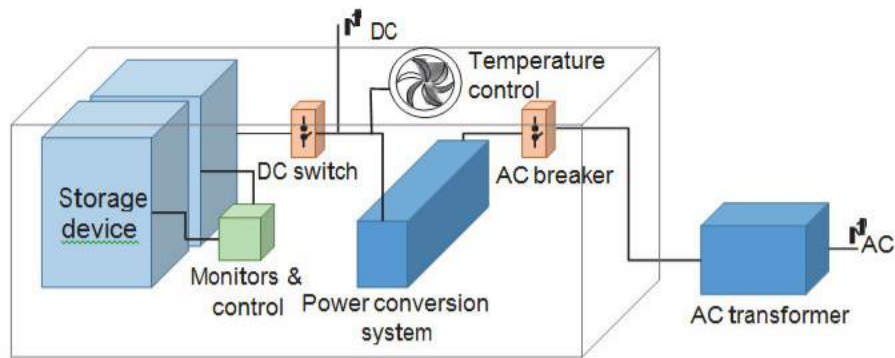

**Figure 1-2 General schematic of a BESS facility**

#### **INTERNAL ACCESS ROAD TO WTGs**

An internal access road between the Project WTGs will be constructed to link the proposed project to the Nukus 1 & 2 projects common switchyard area, which is where the external access road to the site currently terminates. This internal road linking the WTGs will be approximately 20.5 km in length.

#### **OVERHEAD TRANSMISSION LINES (OHTL)**

A 220-kV double-circuit OHTL will transfer power generated from the common switching station to the existing 220/110 kV Beruniy substation. This OHTL spans approximately 44 km in length.

There will be an internal OHTL of 14.5 km connecting the wind farm substation to the existing Nukus 1 switching station. There will also be a shorter 1.5km internal OHTL running in a similar alignment from the Nukus 2 BESS plant to the existing Nukus 1 switching station.

The OHTL design will include cables suspended above ground by metal towers, examples of which are shown below for context only.

### Suspension Tower



### Angle Angular Tower



**Figure 1-3 Example of Typical 220kV Suspension & Angle Angular Towers**

#### OPERATIONS AND MAINTENANCE FACILITY

The Project will include an Operations & Maintenance (O&M) building, which will be part of the substation area and therefore there will be no additional land take for this facility. The O&M building will be used to:

- Provide security to the Project;
- Support the day-to-day operations of the Project;
- Store key spare parts;
- Manage wastes generated by the Project.

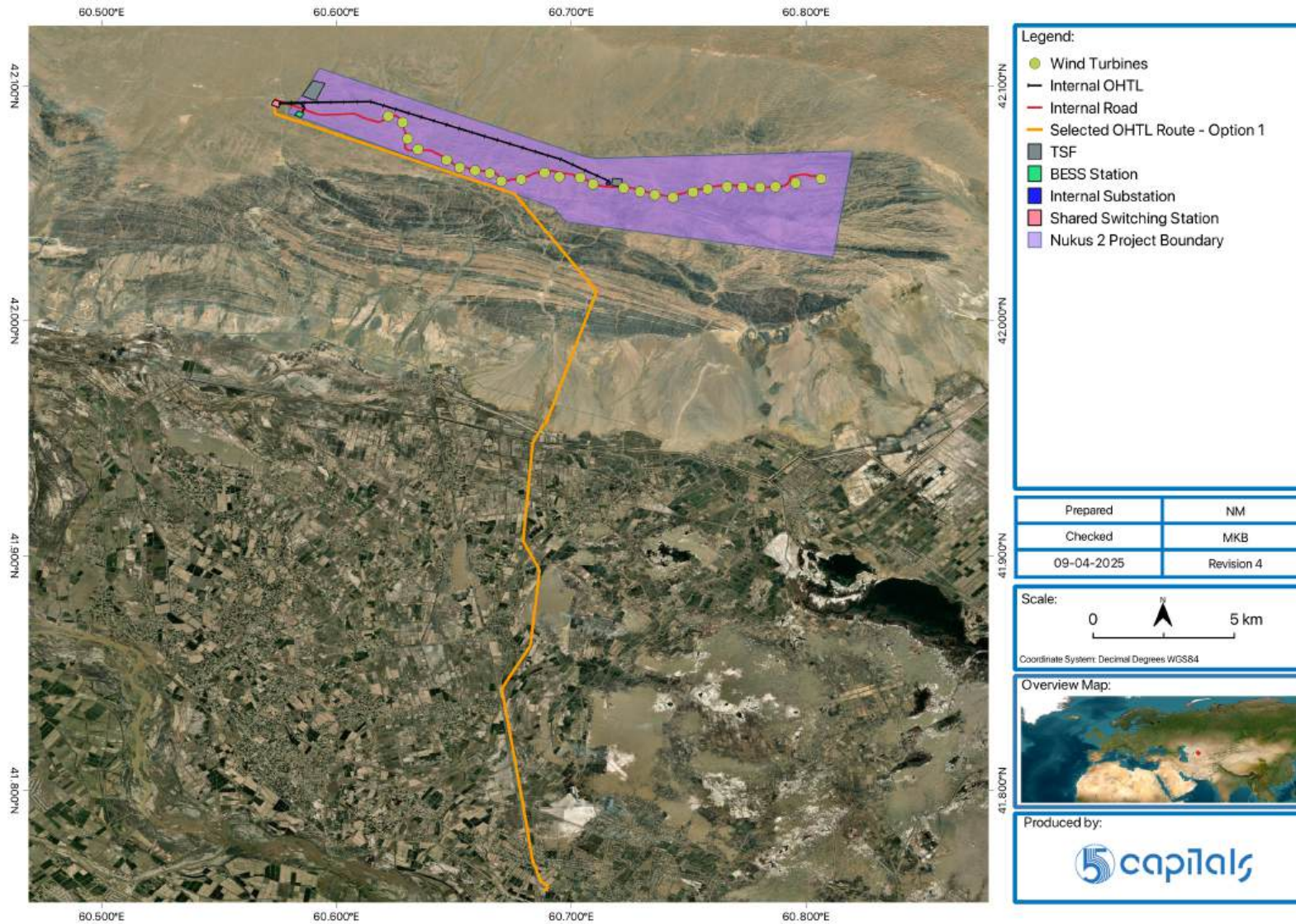

Figure 1-2 Project Layout

### 1.3.2 Shared Facilities

As outlined below, the Project will utilise/share several existing facilities that are in place locally for the Nukus 1 WF project and other infrastructure.

#### **NUKUS 1 WF - ACCESS ROAD**

The Project site is separated from surrounding roads and the regional A380 highway by the Karatau hills. The Project will utilise the existing access road that was constructed by the EPC Contractor for the Nukus 1 WF project. This access road connects to the existing road network and leads to the Nukus 1 temporary site facilities area and the existing EPC Contractor temporary accommodation area. This is adjacent to the Nukus 2 WF TSF area and where the internal site road that will connect to this access road to enable transit between the WTGs.

The Nukus 1 access road is currently in use and is shown in the images below.



**Figure 1-4 Existing Nukus 1 WF Access Road (photographs from EPC Contractor)**

## NUKUS 1 WF – TEMPORARY CONSTRUCTION WORKERS ACCOMMODATION

The existing Nukus 1 accommodation area will be expanded so the EPC Contactor staff can stay in this same area and make use of this as an optimised approach (as it is under the same contractor), which will also lessen the burden for new construction requirements.



**Figure 1-5 Existing Nukus 1 WF Temporary Construction Workers Accommodation (photographs from EPC Contractor)**

Sub-contractors will construct temporary workers accommodation in the Main TSF area of Nukus 2 WF area, which will be located in close proximity to the existing Nukus 1 WF accommodation area.

There will not be dedicated workers accommodation constructed in areas off-site. However the EPC Contractor has advised that certain sub-contractors may need to seek guest houses/hotels in local area for a small number of workers. Where appropriately skilled workers are available locally (locally to the project or elsewhere within Uzbekistan) the EPC Contractor aims to engage 50% of their workers from this pool to lessen the influx burden and need for dedicated accommodation.

## NUKUS 1 WF – TEMPORARY CONSTRUCTION POWER SUPPLY

On-site power for construction at Nukus 1 WF is being conveyed from the grid via a temporary OHTL line to the Nukus 1 TSF and accommodation area. The EPC has advised that this line will be extended via an underground cable to the Nukus 2 WF main TSF area (a short distance from the Nukus 1 TSF).

## NUKUS 1 & 2 SHARED SWITCHING STATION

The Nukus 1 WF switching station is still being constructed and is being sized to accommodate the load from the Nukus 2 WF project without additional expansion or modification. It will provide a tie in for Nukus 2 WF only.

## EXISTING BERUNIY SUB-STATION

It is understood that the Beruniy sub-station that will not be expanded, but will have some modifications to allow a tie-in the OHTL from the Nukus 2 OHTL.

## 1.4 Associated Facilities

Due to the shared facilities outlined above there are not specific associated facilities (outside of the Project's financing) that will be constructed, or expanded to ensure the viability of the Nukus 2 WF project.

## 1.5 Construction Phase Activities and Facilities

### 1.5.1 EPC Contractor

The Project Company will enter into an Engineering, Procurement and Construction (EPC) contract with POWERCHINA - SINOHYDRO. HDEC, the EPC Contractor that is constructing the Nukus 1 WF project is a subsidiary of SINOHYDRO and hence will be able to utilise their experience of working in this area, as well as existing systems and processes. They will also optimise the use of existing temporary construction and accommodation areas, lessening the temporary construction impact.

### 1.5.2 LNTP Works

The Project's early works phase commenced in late December 2024 with certain desk-based studies/works commencing initially prior to site based works that will gradually commence over a period of several months. The EPC Contractor has advised that the following programme is expected for these works.

**Table 1-1 LNTP Schedule**

EARLY WORKS ACTIVITY	SITE
<b>Topography surveys</b>	WF site (28.02.2025 – 20.03.2025)
	220 kV OHTL route (18.03.2025 to 13.04.2025)
<b>Geotechnical survey</b>	WF site and BESS (09.03.2025 – 10.05.2025)
	220 kV OHTL route (10.03.2025 – 30.04.2025)
<b>Temporary Roadworks</b>	WF site and BESS (21.03.2025 – 21.05.2025)
<b>Temporary site facility construction</b>	WF site and BESS (13.03.2025 – 13.05.2025)

A full Notice to Proceed (NTP) is planned to be issued 4.5 months after the LNTP date, by which time supplementary management plans to this CESMP will have been prepared by the EPC Contractor for the main construction works.

Intrusive site-based investigations will only commence following payment of compensation in line with the standalone Land Access Procedure (LAP) alongside the Livelihood Restoration Plan (LRP).

### 1.5.3 Main Construction Activities

The main construction activities will follow the initial LNTP works (above), with the Notice to Proceed (NTP) provided after 4.5 months of LNTP.

The principal construction activities and associated requirements in relation to the wind farm are anticipated to include the following;

- Transportation of components to the Project site;
- Delivery of machinery & equipment to the site;
- Construction of temporary laydown facilities and building site equipment (e.g. containers at the Project site);
- Site preparation (comprising excavation, grading, levelling, and land clearing at WTG platforms) to create flat land area for preparation of turbine pads, installation of wind turbine towers and various project components. Blasting may need to be conducted for hard rock excavation at the WTG pads only, if required as identified by the geotechnical survey;
- Additional facilities to facilitate construction work (comprising excavation and levelling etc.) for access road and the internal road network, construction of any building infrastructure (if required);
- Provision of electricity supply, generation and distribution system as required for installation, including temporary overhead lines connected to the national grid;
- Erection of WTGs;
- Construction of the substation and BESS;
- Commissioning tests of electrical infrastructure (including WTGs) and inspection of civil engineering quality records.

Principal construction activities for the OHTL and access road are anticipated to include:

- Site preparation (comprising excavation, grading, levelling, and land clearing at tower footprint, OHTL corridor and access road alignment);
- Transportation and delivery of equipment/machinery and OHTL components;
- Construction of platforms for pylons/towers and delivery of materials along OHTL route;
- Assembly of OHTL towers/pylons;
- Installation & erection of OHTL towers/pylons, installation and laying of wires & transmission cables on pylons, connecting wires and cables, stringing of conductors, tensioning and sagging of conductors;

- 
- Construction of gravel access road and local strengthening if required; and
  - Provision of electricity supply, generation and distribution system as required for installation, erection, etc.

#### 1.5.4 Temporary Site Facilities

Temporary construction site facilities will be established adjacent to the site boundary allocated for the WTGs (within the site boundary of the Nukus Phase 1 Project). Additionally, a separate laydown area will be set up within the footprint of the Nukus Phase 2 Project, where a batching plant may also be located (to be confirmed – as may also be shared with the Nukus 1 WF project batching plant). After completion of construction, the construction laydown areas will be disassembled, and the area will be returned to its original condition. The laydown area will include:

- Office containers;
- Storage areas for equipment;
- Parking areas;
- Bathroom and waste collection facilities;
- Equipment for power generation (temporary diesel generators);
- Communications equipment; and
- Other miscellaneous small items as required.

The location of the TSF areas are shown in the following figure.

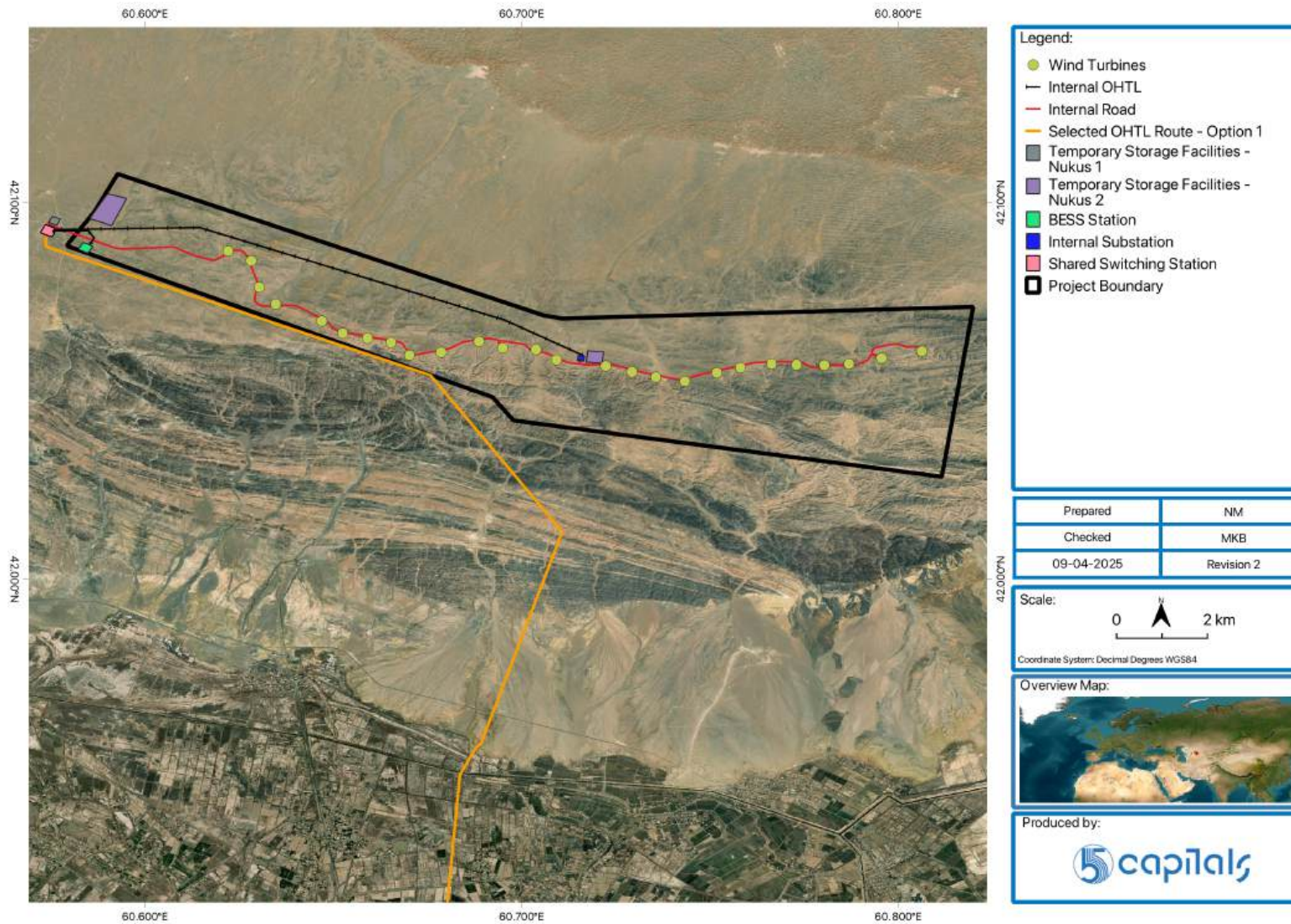

Figure 1-6 Nukus 1 & 2 WF - TSF Areas

Where TSF area(s) will be established along the OHTL corridor/ROW, these areas will be required for the storage of materials such as pre-assembled tower sub-structures, for the further assembly of these sub-structures into final tower structures, for storage of foundation reinforcement steel or steel tower metal bars, tools & equipment to be used by the EPC Contractor as well as sub-contractors responsible for OHTL construction.

After completion of construction, the laydown areas will be disassembled and returned to its original condition.

### 1.5.5 Construction Workforce and Accommodation

The EPC Contractor has advised that the construction workforce during LNTP is expected to be up to 200 workers, mostly skilled. Following LNTP the workforce will ramp up to a peak of approximately 500 workers and will comprise both skilled and semi-skilled labour. Where available and with appropriate skills, the EPC Contractor is targeting that approximately 50% of the contracted workforce will be reserved for Uzbek nationals and residents of the Projects' affected communities, while the rest of the workforce are expected to be hired from China and other Central Asian countries.

The EPC Contractor will accommodate their expat workers in the existing Nukus 1 WF accommodation area and an extension to this. Sub-contractor workers will be accommodated on-site in the Nukus 2 main TSF area. For certain contractors (e.g. where there are limited workers) accommodation may need to be sought in guest houses and hotels in nearby villages close to the Project. There will not be dedicated worker accommodation areas constructed for the project off-site.

The accommodation quality will align with the local regulatory requirements and the IFC & EBRD Workers' Accommodation: Processes and Standards. This includes providing good quality living accommodation, services and amenities to reduce the need for interaction with local communities. Based on experience from other construction sites, this accommodation is expected to be dedicated for EPC Contractor and possibly Project Company and other specialist staff. It is likely that the sub-contractors, if necessary, will need to arrange for alternative accommodation facilities for their workers, which may also be off-site. Sub-contractor accommodation will also align with the Project standards for worker accommodation.

The EPC Contractor has advised that an amount of local (Uzbek) sub-contractor workers' cannot be accommodated in the existing Nukus 1 accommodation area during LNTP and that they are expected to be accommodated in hotels/guest houses in the nearby villages close to the Project footprint, such as in Kepchuk village. The EPC Contractor has advised that this will only be on the basis of having designated floors exclusively for labourers, ensuring

privacy and minimal interaction with other guests through separate entrances and lockable doors. Suitable amenities, including comfortable beds, clean toilets, and safe drinking water, will be provided. Additionally, fire safety equipment will be available.

### 1.5.6 Site Worker Welfare

The EPC has advised that similar to the arrangement to Nukus 1, they will be providing welfare containers that move alongside the works. This is common for works in the wind farm area (i.e. at WTG platforms) and along the OHTL, with the welfare areas along the OHTL lines moving more frequently as works will only be in these areas for short durations.

These are rest shelters with ventilation, heating/AC (depending on the weather), which includes tables & chairs for resting and taking lunch breaks. Space for praying is also available in these containers. Clean drinking water will also be provided. A separate portable toilet with handwashing facilities will be provided. The welfare facilities will be inspected on daily basis by EPC Contractor's E&S Team.

## 1.6 Project Operation and Maintenance

Under the Power Purchase Agreement (PPA) the Project is contracted to supply power for 25 years, upon which time it would either be decommissioned or the assets transferred.

Operations and maintenance activities will be conducted by ACWA Power's wholly owned subsidiary 'NOMAC'.

### 1.6.1 Activities

Wind farms generally require limited operational activities such as:

- Routine daily operation of equipment including maintenance (electromechanical and housekeeping) to optimise energy yield and life of the system;
- Remotely activated turbine shutdown during excessive wind speeds;
- Management of operations in relation to resident bird and bat species (summer and winter) and migration periods during Spring and Autumn (if required); and
- Routine planned preventative maintenance and unplanned maintenance (if required).
- Preventative maintenance specific to the BESS facility include battery health monitoring, thermal management, and the maintenance of the HVAC system.

### 1.6.2 Workforce

A permanent workforce of between 10 – 15 will be required with up to 5 temporary employees. Recruitment efforts will primarily focus on sourcing labours locally and regionally, including from

neighbouring countries within Asia. In cases where specialized expertise is required, recruitment may extend internationally to meet specific operational needs. The Project will not require shifts and the working period of all employees will be 8 hours, shifts are not required as the site can be remotely supervised by SCADA and employees will be on-call if required.

## 1.7 Key Project Milestones

**Table 1-3 Key Project Milestone/Timeline Dates**

MILESTONE	DATE
Project Award	20 <sup>th</sup> December 2023
Signing of Power Purchase and Project Agreement (PPPA) and Grid Service Agreement (GSA)	28 <sup>th</sup> March 2024
Signing of EPC & O&M Agreement	TBC
Limited Notice to Proceed (for certain construction surveys and limited works (geotechnical surveys, topographical surveys, internal road construction and construction of site temporary facilities)	Late December 2024
Target Financial Close (FC)	28 <sup>th</sup> March 2025
Full Notice to Proceed (Construction)	4.5 months after LNTP
Project Commercial Operation Date (PCOD)	Wind Farm: 18 months from FC
	OHTL: 12 months from FC

## 2 WHERE IS THE PROJECT LOCATED?

The Project is located in the Karakalpakstan Republic between Qoraozak and Beruniy districts at range of Sultanuizdag mountains. The nearest cities to the Project area are Urgench (Khorezm region, 57 km) and Nukus (Karakalpakstan, 120 -140 km).

The 220 kV overhead transmission line (OHTL) of approximately 44 km in length will connect the switching station and BESS to the existing Beruniy grid substation located just inside the buffer zone of the lower Darya Biosphere Reserve. Approximately 20 km of the OHTL route goes through mountains and desert area, while the remaining part crosses agricultural fields in close proximity to living houses and structures.

The overall size of land allocated for the development of the wind farm is approximately 6,500 hectares at an altitude ranging from approximately 320 – 380 m above sea level (asl). This area is designated for the construction of the WTGs, BESS, proposed substation, internal OHTL, and internal access roads. While the overall area has been allocated, the footprint areas for components are much reduced from this.

A Land Lease Agreement (LLA) will be prepared between the Ministry of Energy (MOE) and the Project Company for both Wind Farm and OHTL route<sup>1</sup>. Once the OHTL is built and operational, the land area permanently acquired for the OHTL towers will be transferred from the Project Company to JSC “National Electric Grid of Uzbekistan” (NEGU).

The overall size of land allocated for the development of the wind farm is approximately 6,500, however the land allocation for the footprint of the different Project components is as provided in the table below.

**Table 2-1 Land Allocated to the Project**

PROJECT FACILITIES	No./TOTAL KM	FOOTPRINT AREA IN HA	TYPE OF OWNERSHIP
WTG Base (including foundation & hardstand & WTG transformer)	26	19.5	Land lease for project lifetime
Access roads	24.7km	22.5	
BESS	-	5.57	
Wind Farm substation	-	2.09	
220kV OHTL	44km, with 178 Towers	7.12	
<b>Sub-total for Permanent Land Take</b>	<b>n/a</b>	<b>52.06</b>	<b>n/a</b>
Temporary Construction Site Facilities area	-	52.72	Temporary, for use during the

PROJECT FACILITIES	No./TOTAL KM	FOOTPRINT AREA IN HA	TYPE OF OWNERSHIP
(Temporary site facilities, laydown yard, offices, other storage, accommodation camps)			construction phase
<p><b>Note:</b> The project footprint areas have been confirmed by the EPC Contractor. This is not the overall land allocation, but estimated size of the affected footprint of project facilities that will fall under the land lease, or temporary construction use respectively. Additionally, the 2.4ha of land required for the OHTL is based on the tower footprint and it does not include the restrictions on land use that will be established as part of the HPZ on each side of the line.</p>			

Although the design is largely fixed, final locations and footprint size of project components will depend on various factors such as topographical and geotechnical considerations once the LNTP works have been undertaken.

The following figures depict the locations of the Project in the national and local context.

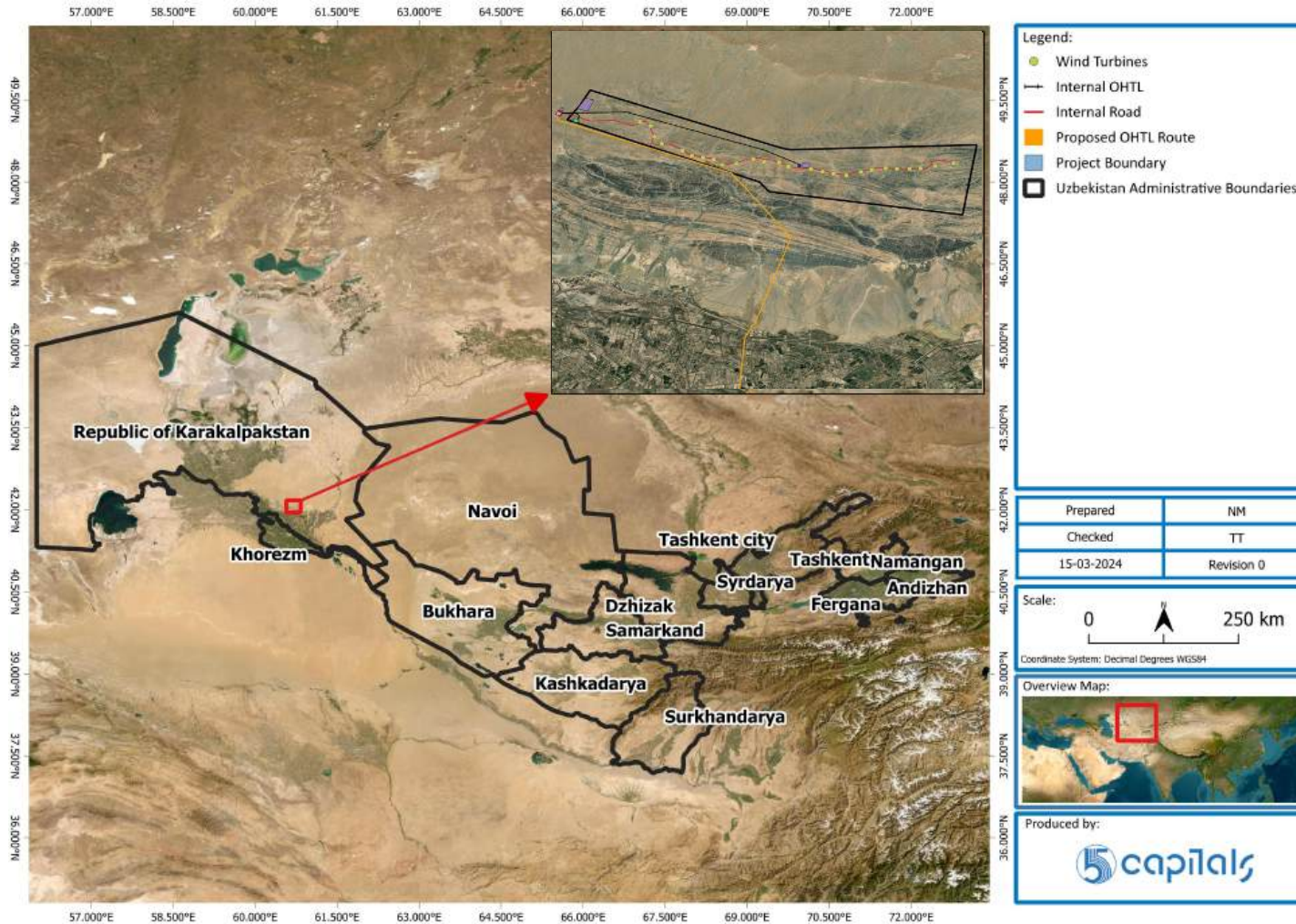

**Figure 2-1 Project Location – National Context**

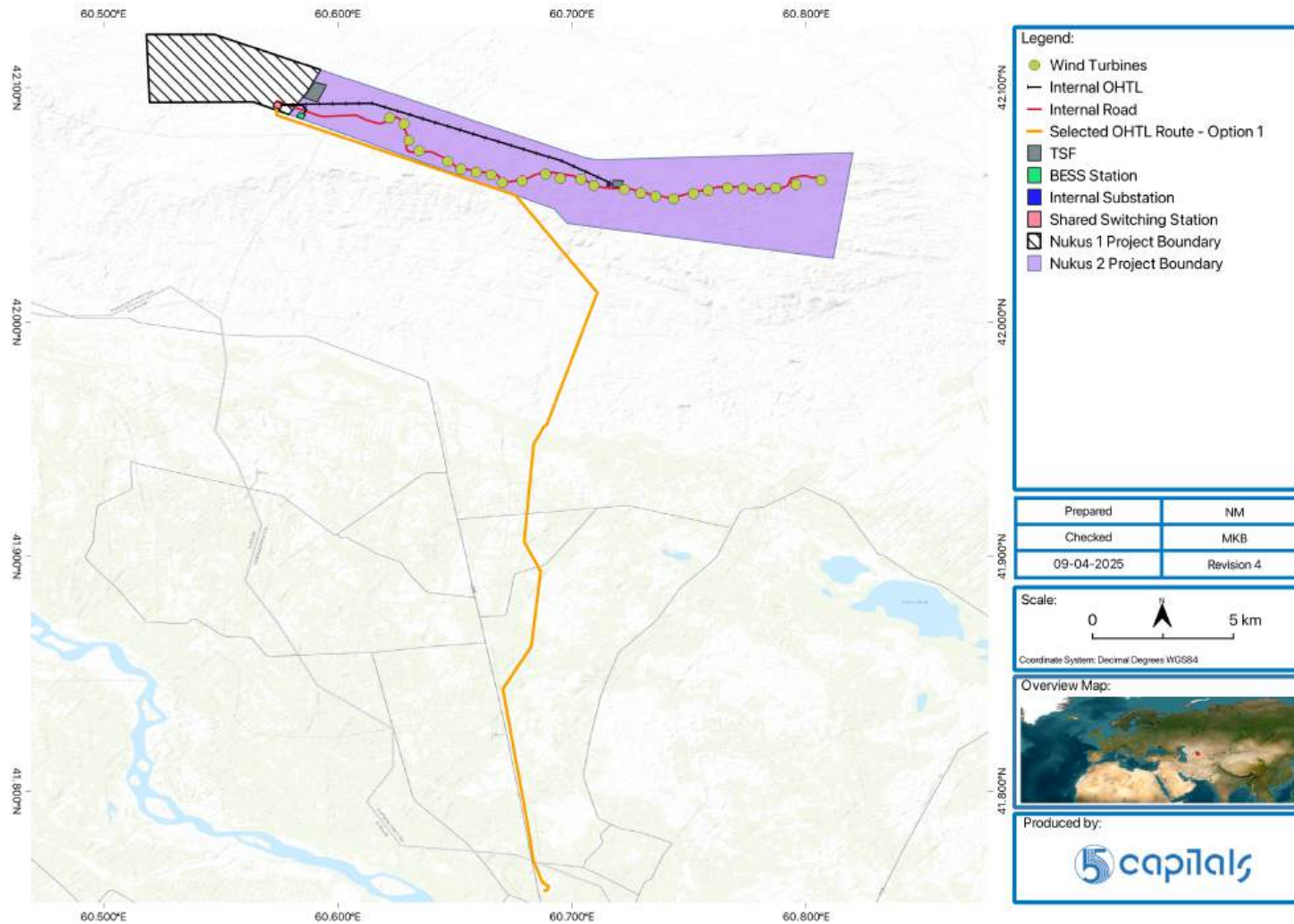

**Figure 2-2 Project Location – Local Context**

## 3 WHAT IS THE CURRENT SITUATION?

### 3.1 Land Ownership

According to the 1998 Land Code of the Republic of Uzbekistan, all land in Uzbekistan is state property and permits for use of land are granted and monitored by the State through the regional and district administrations. In 2021, the Government of Uzbekistan reformed the land allocation process by introducing an e-auction system. As a result, local authorities are no longer authorized to allocate land plots directly to individuals or legal entities. Currently, both land leases and land purchases are conducted exclusively through the e-auction platform.

Land within the wind farm site and along the proposed OHTL route is owned/leased by 49 different groups including private enterprises, individuals, and state organisations, including a 266,340-hectare plot covering the WTG area designated for agriculture and managed by the State Committee for Sericulture and Wool Development Industry (SWID), leased to Beruniy Karakul LLC for 49 years.

Despite the agricultural designation, the extreme climate and poor vegetation limit grazing suitability. Seasonal herders from nearby communities informally use the site during favourable weather, utilizing temporary structures. Nomadic herders may also sporadically use parts of the vast leased land, though no permanent structures or consistent grazing patterns were identified.

Surveys and consultations indicate that the herders' presence is transient, with movements influenced by pasture availability. Residential areas near the OHTL route are outside the 50-meter health protection zone and remain unaffected. A Land Lease Agreement will be established between the Ministry of Energy and the Project Company for the wind farm and OHTL. Upon completion, land acquired for OHTL towers will be transferred to the National Electric Grid of Uzbekistan.

### 3.2 Land Use and Site Conditions

#### WIND FARM SITE

The proposed wind farm site is situated in a desert area on the Sultan Uvaiz Plateau, approximately 9 km from the nearest communities. The plateau features low-mountain plains, gravel deserts, and sandy areas with some drainage channels. The land transitions into agricultural fields separated with irrigation canals to the south. Site surveys confirmed no permanent settlements within the wind farm area, although signs of livestock grazing, including horses and stone cairns used by herders for navigation, were observed in the northwest.

Six seasonal herders, primarily from nearby communities, graze their livestock on the WF site during spring and early summer and use temporary structures (such as fences, watering facilities, and movable vans), which are owned by the herders themselves. These herders operate informally without agreements with either the landowner (SWID) or the leaseholder (Beruniy Karakul LLC).

Construction activities will temporarily restrict herders' access. During operations, herders will be able to return but will face restrictions on siting temporary or permanent structures within the 250-meter Health Protection Zone around wind turbines, while fenced project components like the substation will limit access further.



Sultan Uvais Plateau



High part of the southern slope of the Plateau



Mining on the southern slope of the Plateau



Settlements and arable land

**Figure 3-1 General Landscape at the Wind Farm Site**



Stone cairn on top of the hill



Fresh livestock excrement



Horses grazing on top of the hill

**Figure 3-2 Land Use at the Wind Farm Site**



**Figure 3-3 Herders' structures at the Wind Farm Site**

OHTL

The proposed OHTL, spanning approximately 42-44 km, is located entirely within Beruniy District. About half of the route traverses arable land and populated areas, with land predominantly used for agricultural purposes. The corridor is characterized by crop fields, decorative and fruit trees, irrigation channels and drainage ditches, residential structures, warehouses, and infrastructure such as gas and water pipelines and communication cables.

Approximately 90% of the land affected by OHTL towers is used for agriculture, while the remaining land is managed by residential landowners and state organizations. Impacts will therefore include economic displacement from temporary land use during construction and permanent restrictions on land use in certain areas, including at two commercial stores.

#### ACCESS ROAD

Project vehicles will gain access to the WF site using the existing access road developed for the Nukus 1 WF project. In the areas occupied by agricultural fields (i.e. along the OHTL), movement is possible along dirt and asphalt roads, though driving along some of those routes is challenging for larger vehicles. Country roads are not used frequently by cars. Trucks typically travel along the two-lane roads running along the slopes of the Sultan Uvais plateau.

### 3.3 Nearby Communities

The WF distance to the nearest residential area is 9 km. Meanwhile, the OHTL route runs through a highly modified area represented mainly by agricultural fields with nearby residences.

There are five (5) primary residential communities located in the Areas of Influence (Aol) of the OHTL: Abay, Kyzyl Kala, Dustlik, Nayman and Makhtumkuli.

The figure and table below demonstrates distance of WF and OHTL with regards to nearest communities.

**Table 3-1 Proximity of Local Communities**

COMMUNITY NAME	DISTANCE TO WF PROJECT BOUNDARIES	DISTANCE TO OHTL CORRIDOR
Kyzyl Kala	9 km	4.4 km
Abay	9.5 km	4.3 km
Dustlik (split into two areas)	10 km	80m
	Out of Area of Influence (Aol) of WF	420 m
Makhtumkuli	Out of Aol of WF	OHTL route goes through the area of this village
Nayman	Out of Aol of WF	190 m

### 3.4 Potential Human Receptors

The potential human receptors to impacts arising from the Project are considered to be:

- Herders and their households;
- Farmers, shop owners, and owners of residential land plots with property along the OHTL corridor;
- Residents within the project-affected communities, particularly those based along the OHTL route;
- Utilities and social service providers;
- Vulnerable groups & women who can be affected disproportionately;
- Workers working within the supply chain;

Participants of local/regional economy and of the employment market

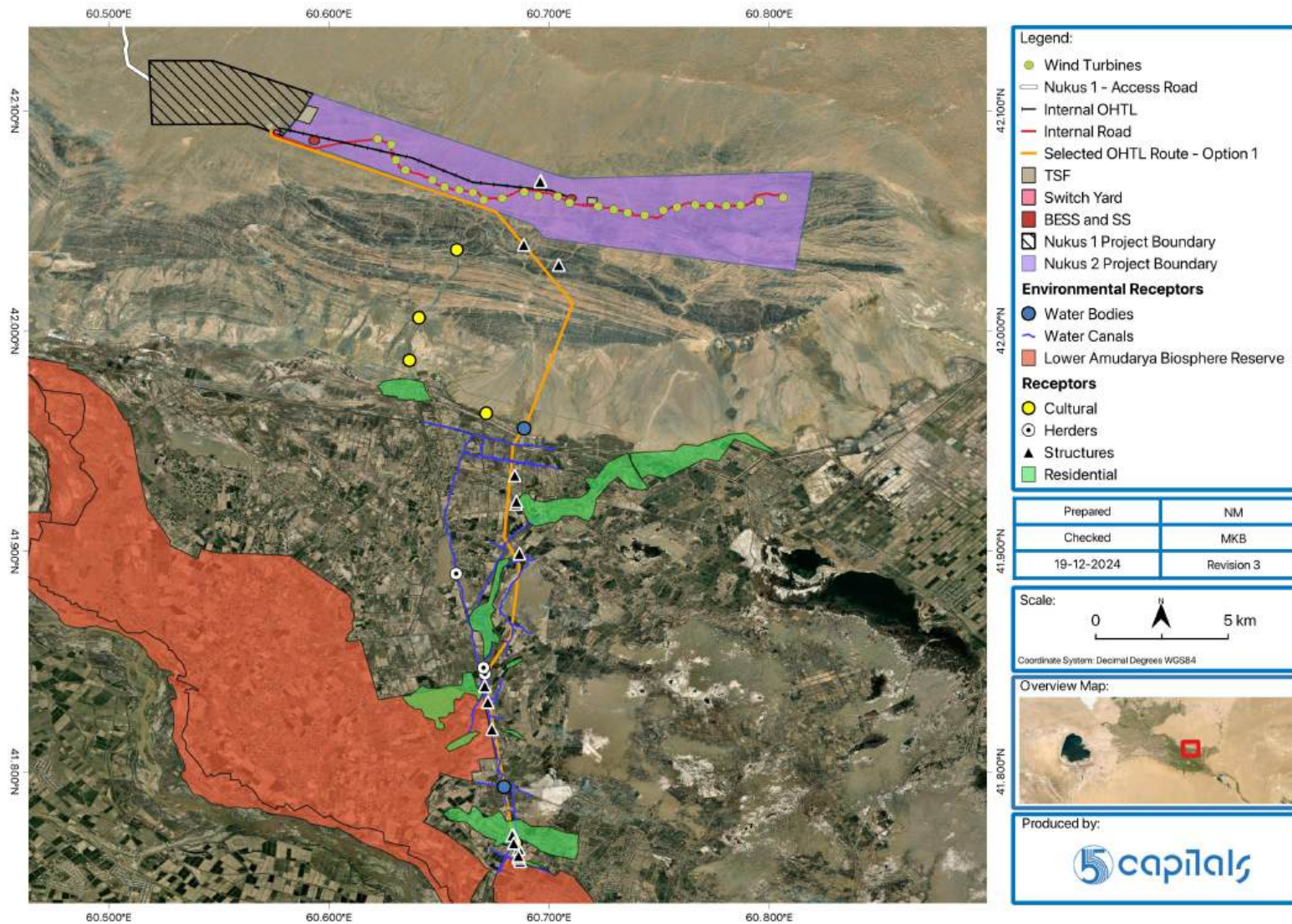

Figure 3-4 Sensitive Receptors Identified around the Project Area

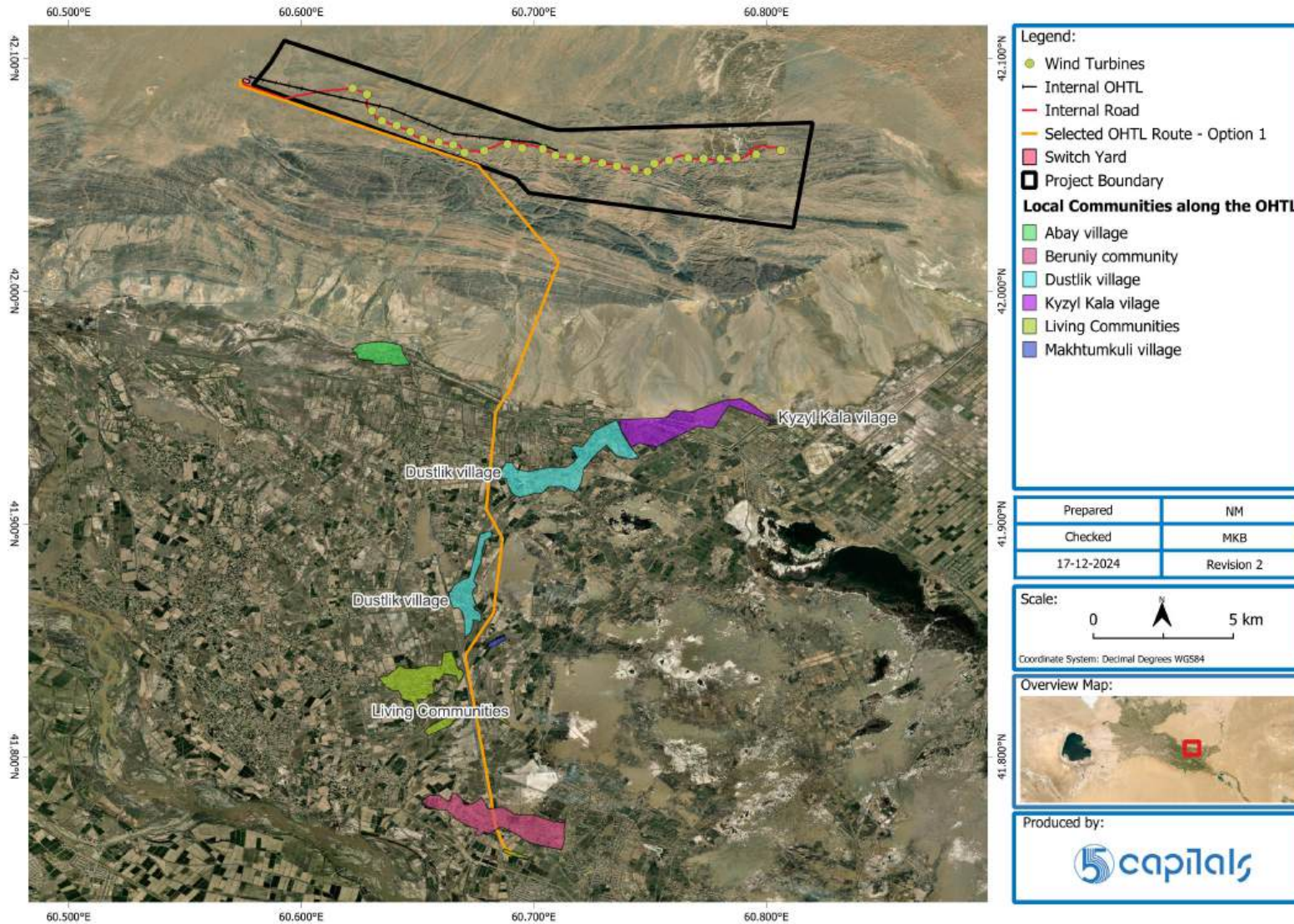

Figure 3-5 Local Communities

## 3.5 Ecology

### PROTECTED AND DESIGNATED ECOLOGICAL AREAS

The southernmost part of the Project's OHTL interconnection at the existing Beruniy substation is located just inside the "transition" zone of the Lower Amu Darya State Biosphere Reserve. However, the Project does not impact any of the Tsugai forest habitat, which supports the nationally important Bukhara Deer and will not result in significant adverse impacts to this transition zone, adjacent to the protected area or its associated biodiversity values. The Spring 2024 botanical baseline surveys confirmed that the OHTL does not cross any patches of Tsugai forest.

There are no Key Biodiversity Areas (KBA) in the immediate project area, with the closest being approximately 45km to the south of the wind farm.

### HABITAT TYPE

The wind farm area, plus the northern ca. 21.5 km of the OHTL are comprised of natural habitat as per the IFC PS6 definition, representing a mosaic of four distinct natural vegetation associations, all within the larger Kyzylkum desert biome. As the Project's OHTL heads southeast out of the wind farm area and then southward out of the mountains, after roughly 21.5 km it crosses an abrupt ecological transition as it enters the irrigated agricultural landscape of the Amu Darya floodplain, where it continues for another ca. 21.9 km southward through a mix of four different types of Modified Habitats (MH), per the IFC PS6 definition, terminating at the Beruniy substation.

### FLORA

With regard to flora, among the 89 plant species of 31 families recorded within the project area, one species, the nationally endemic *Lepidium subcordatum* (Brassicaceae), is red-listed at the national level (i.e., is recorded in the Uzbekistan Red Data Book). It is considered a Significant Biodiversity Value (SBV) for the Project under IFC PS6.

### MAMMALS

For non-volant mammals, a total of 23 species were recorded during the spring mammal survey, four of which are listed in the Uz RDB and the IUCN Red List: the Brandt's hedgehog (*Hemiechinus hypomelas*), Corsac Fox (*Vulpes corsac*), Marbled Polecat (*Vormela peregusna*) and Goitered Gazelle (*Gazella subgutturosa*). Additionally, the African Wildcat is listed under Appendix II of the Convention on International Trade in Endangered Species (CITES), while the Goitered Gazelle is listed under both Appendix II of CITES and Appendix II of the Convention

on Migratory Species (CMS). From the CHA, the Goitered Gazelle and the Marbled Polecat do not trigger criticality but are still considered To meet threshold for inclusion as SBVs.

The Bukhara Red Deer (*Cervus elaphus*) does trigger a CH determination under IFC criterion 1c due to its nationally listed status as an endangered subspecies (*C. e. bactrianus*), although it was not observed during the survey. We note that the occurrence of this species within the Project's EAAA is sporadic, ephemeral, and limited, as the EAAA does not include this species' primary habitat (Tsugai riparian forest).

#### **HERPTILES (REPTILES & AMPHIBIANS)**

For Herptiles, only one (1) species of heightened concern was recorded. The Central Asian Tortoise is listed as Vulnerable on the IUCN Red List and the Uzbek RDB. It is considered a SBV on the basis of its global VU status, and it is present at the site, with 40 individuals documented in the wind farm area during the baseline surveys.

#### **BIRDS**

For birds, a four-season, one-year Vantage Point survey was conducted on the WTG site boundary between March 2021 – March 2022 that recorded 72 species of birds, of which 2 are globally and nationally threatened species, 1 is nationally threatened species, and 2 are nationally threatened species, qualifying as SBVs within a Biodiversity Action Plan (BAP). Large migratory flocks of the Common Crane (*Grus grus*) species flying over the wind farm site, although a common species, has led to a CH determination under IFC CH criterion #3.

#### **Bats**

Surveys were undertaken in the warmer months between April and October 2024. A total of six bat species were identified from the bat detectors, with all species classified as Least Concern by IUCN and are not included in the Uzbekistan Red Data Book. Overall seasonal patterns suggest a ramping up of bat observations from April to September. Activity during the breeding season (June-August) is higher than earlier months, but still low, with a peak of activity detected in September. Activity was observed to drop of significantly in October and was almost negligible during the periods of November that were surveyed.

Full details on the baseline surveys and Critical Habitat Assessment (CHA) are presented in Volume 2 and 4 of the ESIA.

### **3.6 Other Local Environmental Influences**

Besides the Nukus 1 Wind Farm construction and future operations, the wind farm site is largely unaffected from anthropogenic activity, such as air emissions, noise, discharges, or other pollution. Animal herds in the area graze some of the vegetation, but besides this the general

area is largely unaffected. When the Nukus 1 WF is operational, there will be some impacts of noise, shadow flicker and obvious landscape and visual impacts in the specific area of the Project site and immediate surroundings.

Within the wider region surrounding the Project there are vermiculite mines and cement factories (both approximately 10 km from the site boundary for the WTG) with stack emissions visible from the Project site. There are no significant sources of noise and vibration, but ground conditions mean the potential for soil erosion and dust generation during the Project construction phase are high.

The Project site is located in medium to high seismic hazard level with relatively high values of Peak Ground Acceleration.

## 4 WHAT ARE THE KEY BENEFITS?

### GENERATION OF RENEWABLE ENERGY

At a strategic level, the Wind Farm represents a significant step toward a low-carbon transition for Uzbekistan's economy by harnessing the country's wind resources. The Project aligns with the Uzbekistan 2030 Energy Strategy by reducing the country's dependency on fossil fuel-generated power and decreasing atmospheric pollution. Fossil fuel-based power plants are major contributors to carbon dioxide and other harmful emissions, which contribute to current human induced climate change and air pollution. Generating electricity through wind farms will significantly decrease these emissions, promoting cleaner air and a healthier environment. It supports the sustainable growth of the national economy through a reliable and renewable power supply.

Access to reliable and sustainable energy can also improve the quality of life for communities, particularly in remote areas where electricity access may be limited or unreliable. With stable and clean energy, there are improved prospects for education, healthcare, and overall socio-economic development.

### PROJECT EMPLOYMENT AND ECONOMICS

An economic impact during the construction phase is expected to arise from employment opportunities generated by the project within its limited timeline. The project will offer jobs for both unskilled and appropriately skilled workers. The EPC Contractor has advised that they will target to employ 50% of local workers (from local communities or Uzbekistan), where suitably skilled people are available. This is in part to minimize socio-cultural conflicts that might arise from an influx of non-local workers. Overall there are expected to be 500 workers required at peak construction.

Employment on the project will provide direct financial benefits to the families of the employed workers. Additionally, wages paid to workers are anticipated to have a positive multiplier effect on the local economy, whereby workers spend their earnings locally, thereby stimulating further economic activity and recirculating money within the community.

The operations phase will also create some, employment opportunities, in contrast to the construction phase, fewer jobs will be available, the vast majority of which will be skilled. While the operational workforce is limited in size compared to the construction phase, it offers valuable opportunities for skill dissemination due to the longer duration of employment. ACWA Power's established processes and proven track record suggest that non-technical staff, such as security and support staff, will likely be sourced locally.

The construction phase is expected to generate secondary economic impacts through the procurement of both local and international goods and services. While specialized materials required for the development are likely to be sourced internationally, essential construction materials such as concrete and aggregate will be procured locally. This local sourcing is expected to benefit local suppliers and contribute positively to the regional economy.

Furthermore, there is potential for an economic boost through the purchase of locally produced food products. Workers' demand for fresh vegetables and daily consumables can provide local farmers and vendors with additional sales opportunities, thereby stimulating local agriculture and retail sectors.

#### **TRAINING AND DISSEMINATION OF SKILL AS PART OF ON-THE-JOB TRAINING**

In addition to the immediate financial benefits generated by employment during the construction phase, the project presents a valuable opportunity for the transfer of skills and knowledge to the local workforce. This includes not only construction and construction support skills but also international best practices in occupational health & safety and environmental & social standards.

Exposure to these advanced standards and techniques through collaboration with expatriate workers will enhance the local labour force's competencies. This skill dissemination is expected to significantly boost the employability of local workers, equipping them with qualifications and experience that increase their chances of securing similar employment opportunities after the project's construction phase concludes. This capacity building can contribute to long-term economic development by expanding the local talent pool and improving workforce readiness for future projects.

## 5 WHAT ARE THE NEGATIVE IMPACTS OR UNCERTAINTIES AND HOW ARE THESE TO BE MANAGED?

### GENERAL CONSTRUCTION DISRUPTION AND IMPACTS TO COMMUNITIES

For the wind farm site, there will be minimal and temporary impacts to human receptors during the construction phase (such as dust, air emissions, noise lighting, vehicles etc.), due to the lack of residences and only a few land users (6 herders who use the land in and surrounding the project area). The most significant impacts at the wind farm site, may relate to noise and dust from blasting (if required) in the WTG pad areas in the event of hard substrate being identified during the geotechnical surveys. Other impacts are (in general) expected to be minimal and can be managed through the application of appropriate mitigation outlined in the ESIA, with on-going monitoring.

During WTG installation phase, there will be long and oversized vehicles delivering WTG components to the site, which will temporarily affect traffic along haul routes, including the A380 and the Nukus 1 WF access road. Impacts will primarily be to road users of the A380, as the Nukus 1 WF access road is for access to the project and is not expected to be used by communities. The EPC Contractor will implement a traffic management plan similar to what they implemented for the Nukus 1 WF project, with the intention of limiting disturbance to road users and communities.

Along the OHTL route, construction will only likely last a few days/up to a week at any one location as the nature of the works will move along this linear infrastructure. Certain temporary facilities areas will be semi-permanent for the duration of construction, including for modification works at the existing Beruniy substation to allow the OHTL tie-in to the grid. Works along the OHTL will result in the presence of construction teams, their vehicles and equipment, which is expected to result in temporary air quality and noise impacts. Certain wastes will also be generated but managed in accordance with the common practice mitigation measures outlined in the CESMP.

The EPC Contractor has developed an LNTP Phase Construction Environmental & Social Management Plan (CESMP) for early works and will further develop a full CESMP and broader array of supporting E&S management plans/documents as part of their construction phase Environmental & Social Management System (ESMS), which is further outlined in Volume 3 of the ESIA. Most of these documents will build on the systems and processes implemented by the EPC Contractor during their work on the Nukus 1 WF project.

During operations, there are not expected to be significant disruption to communities besides those outlined below relating to visual and landscape impacts. It is possible the occasional maintenance may be required, which may pose similar temporary impacts to those experienced during construction.

### **ECONOMIC DISPLACEMENT**

Surveys conducted for the LALRP identified a number of affected households, private enterprises, and state organizations that may be affected by the Project and LNTP works. Informal land users have also been identified, including herders and small-scale farmers.

#### LNTP Phase

The construction of the Project will result in economic displacement only. No permanent land take is expected at LNTP stage both for Wind Farm and OHTL, but the EPC Contractor will require temporary access to drill boreholes at the proposed locations of WTGs and OHTL towers. As evictions or termination of land-use rights will not occur at this time, relevant project-affected entities (i.e., PAHs, private enterprises, herders etc.) will be allowed to maintain their respective livelihood activities on site. The total number of Project Affected Households (PAHs) and Project Affected Persons (PAPs) has been outlined in the LALRP specifically.

Access to land will be undertaken in accordance with the Land Access Procedure with compensation for expected impacts paid prior to impacts. Any unanticipated or incidental impacts will also be compensated in accordance with measures stated in the Entitlements Matrix as part of the Project's LALRP.

A detailed discussion of the impacts caused by land acquisition has been prepared in the standalone Land Access Plan (LAP), which is specific to the construction phase. The full entitlements matrix for the LNTP (and full NTP) is provided in the standalone Land Acquisition and Livelihood Restoration Report (LALRP) prepared for ACWA Power.

ACWA Power/the Project Company will be responsible for ensuring that PAPs receive agreed-upon compensation packages and opportunities established through meaningful consultation as outlined in the LALRP to improve or at least restore their means of income-earning capacity, production levels and standards of living prior to the commencement of impactful works.

#### Main Works

Construction in the wind farm area will impose temporary land use restrictions to fenced working areas for the six (6) informal herders who have access to this land. After construction, herders will be able to return to resume their grazing activities in the project development area, except for the land footprints that will be used for the project facilities, which will have been

modified and will be permanently acquired from the State Committee for Sericulture and Wool Development Industry (SWID) by the Government of Uzbekistan. Acquired land will be allocated to the Ministry of Energy (MoE) of the Republic of Uzbekistan. In turn, the MoE will sign a Land Lease Agreement (LLA) with Project Company.

Along the OHTL, there are some non-residential structures of 34 PAHs, such as barns or toilets located on land within the Health Protection Zone (HPZ) that will face certain restrictions. Additionally, two commercial shops within the Health Protection Zone will be affected.

OHTL tower footprints will be permanently acquired and this will prevent agricultural activity within these areas. The tower footprints will be limited in size and other land surrounding these areas will remain with the existing land users. However, the application of the regulatory Health Protection Zone, will lead to certain land restrictions although farmers can continue crop cultivation within the OHTL Health Protection Zone, as local legislation allows farming activities in such areas.

A comprehensive Land Acquisition and Livelihood Restoration Plan (LALRP) has been prepared separate to the ESIA address compensation and livelihood restoration measures to mitigate these impacts in line with national and lender requirements.

## **ECOLOGY**

Clearing, grading, excavation and other earthworks during the LNTP and early construction stages will result in direct habitat loss in areas of the construction footprint and access roads of the project. This includes project facility areas and temporary laydown areas. Habitat loss in areas disturbed during construction but falling outside of the physical footprint of the project facilities will be reversible and there will be post-construction restoration of affected areas. The LNTP works will be subject to a Biodiversity Management Plan. Including a Biodiversity Monitoring and Evaluation Plan (BMP/BMEP) together with a Biodiversity Chance Find Procedure.

It's important to note that although the design and locations of facilities are largely fixed, there is some potential for minor adjustment based on findings from site surveys during the LNTP phase (e.g. geotechnical survey results). Hence, activities including vegetation removal and earthworks may affect the nationally important *Lepidium subcordatum* that is known to be present in the general project area, as well as certain mammal and reptile species.

The EPC Contractor will hire an Ecologist before the start of LNTP to provide training for EPC and sub-contractors (e.g. geotechnical survey team) and to be on-site before early works to implement mitigation stated in the ESIA and to undertake pre-construction surveys of the working areas, as per the BMP/BMEP and BCFP. The training and pre-construction surveys (site clearance /road access etc) will focus on SBVs and CH species, nests, burrows and roosts. .

Mitigation measures are presented in Volume 2 of the ESIA and will also be developed post BMP/BMEP as part of the construction/operations Biodiversity Action Plan (BAP).

Besides impacts to vegetation and habitats, there is also the risks of vehicular collision, poaching, hunting and gathering, littering, disturbance, pollution, displacement, proliferation of generalist species, and introduction of invasive species, which are intended to be avoided or minimised through the application of mitigation measures stated in the ESIA. These will include training during induction and toolbox talks for EPC staff and subcontractors and also biosecurity measures to prevent invasive species being brought to the site, or proliferation after site clearance of WTG pads and laydown areas.

During the operation phase, there will be limited habitat fragmentation due to the access roads and potentially some avoidance by species that prefer open habitats or are sensitive to tall structures, such as WTGs and the OHTL line.

For birds, the Nukus 2 Wind Farm has a low-moderate level of collision risk for sensitive bird species. Among tier 1 target species (a category that includes all bird species with elevated national and/or international conservation/protected status that potentially occur at the site) only four species have been detected within the specified maximum reliable observation radius during the VP survey effort, to date, and none are predicted to experience annual collision frequency greater than one fatality per 13 years under the most realistic collision avoidance rate parameters modelled. This reflects the extremely low occurrence of tier 1 target species recorded at the site within the rotor swept danger zone, during the VP surveys.

Among tier 2 target species (a category that includes all other raptors and selected additional large bird species that could potentially be sensitive issues for the Project, if impacted), only eight species were detected at the site during the VP survey effort. Of these, the Eurasian Kestrel (*Falco tinnunculus*) was predicted to experience the highest collision rates, with 8.72 collisions predicted per year, followed by the Common Crane (*Grus grus*), for which 4.21 collisions per year are predicted under the most realistic collision avoidance scenario. None of the other tier 2 target species were predicted to experience collisions more frequently than once per year under the most realistic collision avoidance scenarios modelled. Based on these results, the low collision risks will be addressed through the Biodiversity Action Plan, including bird flight diverters and raptor-safe design to avoid electrocution risks, post construction fatality monitoring along the OHTL and the wind turbines, with adaptive mitigation measures to be implemented, including offset measures, if thresholds are exceeded. Measures to offset/reduce impacts on common species such as Eurasian Kestrel will include provision of suitable nest boxes away from the WTGs and applicable measures to keep birds from hunting close to the WTGs.

Bat activity was observed to peak in September, with higher activity in the summer months as expected. The common pipistrelle (*Pipistrellus pipistrellus*) is the only species that is considered of higher risk of rotor collisions based on potential flight height. However, based on the lower sensitivity of the bat species, the ESIA considers impacts on all bat species to be negligible.

The two species triggering CH, Bukhara deer and Common Crane will be subject to specific offset measures to achieve NNL/NG, documented in the BAP.

Habitat restoration will be undertaken for all temporary construction areas including laydown, worker camps, temporary access roads and buffer zones around the site works. This will be undertaken post construction to achieve NNL of natural habitat through enhancement of the floral biodiversity and local quality of the grazing pastures.

### **OPERATIONAL NOISE**

During operations of the WTGs, noise will be generated from mechanical and aerodynamic sources. Both mechanical and aerodynamic noise may result in noise propagation to surrounding off-site areas. The sound power level of wind turbines increases with higher wind speed due to the increase in rotation speed of the turbine blades. A preliminary screening assessment was performed and showed that noise levels are expected to drop to between 35 and 40 dB(A) within 1 to 1.5 km from each WTG. As there are not residential areas within 9km of the WF site, impacts for noise may only relate to herders using the land, as well as to fauna in this area. There are not further specific mitigation measures proposed for noise.

It is noted that the OHTL is not expected to generate significant noise, however corona noise (crackling) will be perceivable in close proximity to the lines (e.g. within the Health Protection Zone) and is likely to be more perceivable during rainy or moist conditions.

### **WASTE**

Waste will be generated during all stages of construction. Typical construction wastes include soil & rock, waste concrete, scrap metal, glass, plastic, wood, packaging materials, excess cables, and domestic waste from workers accommodation. There will also be domestic wastewater and concrete washout water. Construction of many of the key wind farm and OHTL components will comprise the assembly of parts delivered to site (or those that will be fabricated on-site) and therefore the amount of solid waste that will be generated is expected to be minimised. There is expected to be a small volume of hazardous waste generated during construction, such as paints, oil drums, lubricants, fuels etc.

All waste will be managed by the EPC Contractor in accordance with a Waste Management Plan that will mirror the plan in place for the Nukus 1 WF project. This will include provisions for the training of workers in regard to the handling and management of waste on-site. The EPC

Contractor has also confirmed that they intend on engaging the same government licensed waste management companies to handle generated construction waste.

Solid and liquid waste is not expected to be generated in significant quantities during the operational phase of the project as there few consumables and a limited workforce on-site. Certain planned and preventative maintenance activities will generate wastes, some of which will be hazardous for oils/lubricant replacements, paints etc. The operational phase of the project will also implement a Waste Management Plan tailored to the expected operational waste streams and volumes.

### **LANDSCAPE AND VISUAL IMPACTS**

During the construction phase, the Project will steadily give rise to a number of obvious changes to the landscape character and visual amenity, arising primarily from the erection of the WTGs and OHTL. WTGs are tall (i.e. the model to be used for the Project has a hub-height of 138m with additional height to the top of the rotors) and as they will be located in an open and elevated landscape WTGs will be visible at distance alongside the WTGs being installed at the adjacent Nukus 1 WF project. The WTG will present vertical intrusions to the previously largely undisturbed landscape. Further the WTGs will be noticeable due to the rotation of the rotor and blades that will be constantly moving. Impacts will be most obvious to visitors of the Munajat Mountain, with reduced impacts at residential areas, due to distance and intervening topography. A red aviation warning light will be visible on top of the hub for aviation safety purposes, which although small, will be visible at night. Visibility of the wind farm is inevitable and the efficacy of landscape and visual mitigation measures beyond the site selection and layout is extremely limited.

The construction of the OHTL will present a more obvious visual impact to human receptors, as it will run in closer proximity to communities and within the agricultural land. The OHTL will present both a vertical intrusion and linear impact along the alignment. Other OHTLs are present in the local area and hence this is not an unprecedented landscape character impact, but it will be a permanent impact with partial blocked views from receptors.

During both the construction and operation phase, good housekeeping will be implemented to ensure that there are no landscape and visual impacts relating to wastes and litter. In addition, during the construction phase, construction activities will be limited to the areas required and works will not be allowed to spill out unnecessarily.

### **SHADOW FLICKER**

An initial shadow flicker calculation was carried out by Juru (2021). The model calculation showed the expected yearly shadow (flickering) hours at 2 km from the WTG will be less than 10 hours per year. No permanent residential receptors are located within 9 km of the nearest

WTG, and therefore shadow flicker impacts are not expected to be an issue for the Project at residences and other human receptors.

#### **TRAFFIC AND TRANSPORTATION**

Construction activities including the transportation of WTG components and other construction materials will require an increase in vehicular flow on roads and highways and this will likely result in road traffic increases.

Findings from the transport survey and numerous site visits undertaken till date indicates that the highways and local road infrastructure are operating below their respective design capacity and as such have sufficient capacity for increase in traffic flow and will not be significantly impacted by vehicles carrying normal loads. However, the movement of specialised turbine transportation vehicles will cause some disruption to other road users, potentially resulting in instances traffic congestion, that may result in increased journey times.

It is important to note that the route survey report indicates that the route does not pass residential areas but rather is limited to along major highways. A final Route Survey Report and an associated Traffic and Transportation Management Plan will be undertaken by the EPC Contractor.

Transportation impacts during operations are not expected to be significant.

#### **ARCHAEOLOGY & CULTURAL HERITAGE**

No archaeological findings were discovered at the Wind Farm area or along the OHTL route during the archaeological surveys. Known sites of cultural importance are situated at safe distances from project facilities and hence direct impacts are not expected.

The construction phase will involve groundworks, and excavations (possibly including blasting at certain WTG pads – pending outcomes of the geotechnical survey), which could potentially damage unknown historical sites, graves, or archaeological artifacts buried below the surface. To mitigate such risks of damage, a Chance Find Procedure (CFP) should be implemented before starting work.

## 6 ENVIRONMENTAL AND SOCIAL MANAGEMENT AND MONITORING

The Project will incorporate mitigation and monitoring requirements established within Volume 2 of the ESIA as well as requirements and conditions set out by the Uzbek regulatory authorities and the Lenders.

Volume 3 of the ESIA provides an Environmental & Social Management Plan (ESMP) that incorporates the mitigation and monitoring requirements stated in Volume 2 of the ESIA. These will be required for implementation during the construction and operational phases of the Project respectively by the applicable Project parties.

For the construction phase, the EPC Contractor has prepared a LNTP phase CESMP that covers the early-works and they will further develop a full CESMP and related ESMS for the main construction phase. E&S management will be implemented by an E&S team within the EPC Contractor, which will include a HSE Manager, E&S Manager, Ecologist, E&S Coordinator/Assistant and Community Liaison Officer (CLO). Workers will be subject to various E&S training, including as part of their inductions and other specific training.

The O&M Company will develop a similar operational phase ESMS and will engage suitably skilled E&S staff to ensure the implementation of operational specific mitigation and monitoring.

### **INDEPENDENT AUDITING AND MONITORING**

The Project will be subject to periodic independent monitoring in accordance with the requirements of the Lenders. The scope of the independent audits will include the implementation of the Environmental & Social Action Plan (ESAP), the E&S covenant of the loan agreement and will evaluate on-site activities and documented controls and monitoring efforts, with respect to the Project's compliance obligations.

## 7 STAKEHOLDER ENGAGEMENT

Project stakeholders were identified in terms of their relevance to the project to enable a differential engagement strategy, such that the scope, modes and frequency of planned consultation and disclosure were commensurate with the parties' roles, risks, and interests.

Engagement modes included formal correspondence (e.g. letters), community meetings, inventory surveys, leaflets and infographics, and Focus Group Discussions (FGD). Most of the engagement took place in April and May 2024. As part of the National EIA process public hearings were conducted on April 24-25<sup>th</sup> 2024 in the five local communities, namely Abay village, Kyzyl Kala village, Dustlik village, Makhtumkuli village, and Nayman village, to provide project information, introduce the grievance mechanism established for the project and to receive feedback or concerns.

### **DISCLOSURE OF E&S DOCUMENTS**

The Project's ESIA and related E&S documents will be disclosed on the ACWA Power website and the lenders' websites in accordance with their respective E&S Policies. Disclosure of complete ESIA 'working drafts' has already been undertaken by AIB and ACWA Power based on documents prepared and dated 17<sup>th</sup> January 2025.

Disclosure of the LALRP to communities commenced as of 25<sup>th</sup> February 2025.

Hard copies of this final ESIA Volume 1 Non-Technical Summary will be made available in local languages (Uzbek, Karakalpak) and placed at key community locations so that they are easily accessible to those that do not have access to internet.

Those people being economically displaced will be provided with individual compensation packages relevant to either impacts during the LNTP works and/or main construction works. This will be fully outlined in the LALRP and related documentation.

### **STAKEHOLDER ENGAGEMENT PLAN (SEP) AND GRIEVANCE REDRESS MECHANISM**

A project SEP has been prepared separate to the ESIA that outlines conducted stakeholder engagement at ESIA stage as well as how future engagement will be undertaken with the identified project stakeholders; much of this being undertaken and led by the respective CLOs.

A grievance redress mechanism has also been outlined regarding how external parties can lodge a grievance and the processes related to grievance management and follow-up by the project side. The grievance mechanism will be available at key project locations. The information provided will be available in English, Uzbek and Karakalpak.

It is noted that a separate grievance mechanism will be available to the project workforce.

## APPENDIX A – PROJECT CONTACT INFORMATION

COMPANY	CONTACT DETAILS
<b>Project Development – ESIA stage</b>	
<b>ACWA Power (Project Developer)</b> Akbar Mavlonov Senior Manager – Business Development	Block-A, 13th Floor, 107-B, Amir Temur Avenue, Tashkent, Uzbekistan Email: <a href="mailto:amavlonov@acwapower.com">amavlonov@acwapower.com</a> Mob: +998 71 238 9960
<b>Juru</b> Dinara Rustami – Project coordinator	Email: <a href="mailto:d.rustami@juru.org">d.rustami@juru.org</a> Work: +998 71 202 04 40
<b>Juru</b> Gulchekhra Nematullayeva – Social Specialist	Email: <a href="mailto:g.nematullaeva@juru.org">g.nematullaeva@juru.org</a> Work: +998 71 202 0440
<b>Project Development - LALRP stage</b>	
<b>Juru</b> Iroda Malikova Social Specialist	Email: <a href="mailto:i.malikova@juru.org">i.malikova@juru.org</a> Mob: +998 77 067 55 50 Work: +998 71 202 04 40
<b>Juru</b> Yulduz Yusupova Social Specialist	Email: <a href="mailto:y.yusupova@juru.org">y.yusupova@juru.org</a> Mob: +998 91 502 85 33 Work: +998 71 202 04 40
<b>Construction stage</b>	
<b>“ACWA Power Beruniy” Wind FE LLC (Project Company)</b>	TBC
<b>EPC Contractor – POWERCHINA SINOHYDRO</b>	TBC
<b>Operations stage</b>	
<b>“ACWA Power Beruniy” Wind FE LLC (Project Company)</b>	TBC
<b>O&amp;M Company - NOMAC</b>	TBC